

**CHRISTIAN COUNTY HEALTH DEPARTMENT  
WASTEWATER TREATMENT SYSTEMS  
REVISED OCTOBER 1, 2015**

<b>Introduction</b> .....	2
<b>Site Information</b> .....	3
 <b>Chapter I: Christian County Ordinance</b>	
Authority.....	5
Definitions.....	5
Permits .....	6
License and Registration Program .....	7
Powers and Authority of Department Officials .....	8
Operation of Systems; Inspection and Sampling.....	8
Fees .....	9
Penalties .....	9
Appeals .....	10
Severability .....	10
 <b>Chapter II: Requirements for Sewage Permit Compliance</b>	
Application Form .....	12
Permit Application Procedure.....	12
Application Processing .....	12
Construction Procedure.....	13
Permit Duration and Renewal.....	14
Permit Transfer .....	14
Permit Revocation or Suspension.....	14
Temporary Licensing.....	15
License Revocation or Suspension.....	15
Fee Schedule .....	16
 <b>Chapter III: Design and Construction Standards</b>	
Definitions.....	18
Set Back Distances.....	23
Sewage Flow Rates .....	25
Building Sewers .....	27
Sewage Tanks .....	28
Absorption Systems .....	33
Alternative Systems .....	40
Site Evaluation (general).....	27 & 42

## INTRODUCTION

Improper sewage disposal and treatment is a water quality concern for home owners across the nation. Inadequate site information, design, construction, and maintenance of wastewater treatment systems can result in water quality problems, nuisance conditions, and costly repairs to rehabilitate a failing system. Failing wastewater systems are not only those that we can see (and smell), but those that do not surface to the top of the ground but fail to remove the disease-causing organisms before the effluent reaches our groundwater. Some of the common communicable diseases that can be transmitted by improperly treated human wastes are: salmonellosis, shigellosis, giardiasis, amebiasis, infectious hepatitis, campylobacter, clostridium, perfringens, tetanus, diarrhea, yersiniosis, hookworm, cholera, hand-foot and mouth disease, paratyphoid fever, typhoid fever, dysentery, schistosomiasis, poliomyelitis, and staphylococcal.

Numerous studies done by the Missouri Department of Health during 1988-89 show that many on-site sewage systems are failing.

The most common individual system, the septic tank-absorption, has a notorious reputation of failure. Because of inadequate siting, design, construction, and maintenance, many individual systems have, historically, been installed on sites that are not suitable for conventional soil absorption systems. Many advances in technology for proper installation for individual systems have been made since the 1980's.

On-site systems have been plagued by poor public acceptance; feelings that those systems are second rate, temporary, or failure prone. That situation changed in the 1980's when on-site systems began gaining desired recognition as a viable wastewater management alternative that can provide excellent, reliable service at a reasonable cost, while still preserving environmental quality.

In this time of population movement to rural and semi-rural areas, the decline of federal and state construction grants for public wastewater treatment facilities and the high cost of privately owned centralized collection systems, we are faced with the need for more information and control of the planning process, design, construction, and management of on-site systems.

It is vital that the citizens of Christian County protect the natural resources that we are so fortunate to have at very little expense. In order to keep these resources available at a cost level that is not prohibitive for the average citizen of our county, we must and will protect them with all available measures.

The regulations in this booklet are designed to describe and define each step in this protection. The design standards are based on MO Dept. of Natural Resources 10 CSR 20-8.021 and 19 CSR 20-3.060.

In closing, the requirements are spelled out clearly. In a situation that is questionable, the Christian County Health Department has the responsibility to pursue what means are necessary to protect the health, safety and well-being of the citizens of Christian County, Missouri and their natural resources.

## SITE INFORMATION

In general, systems designed to discharge partially treated wastewater to the soil for ultimate disposal, are the most reliable and least costly individual systems. This is because little pretreatment of the wastewater is necessary before application to the soil. The soil, by several different chemical and biochemical processes, can treat the wastewater to an acceptable quality for discharge into the groundwater under the proper conditions.

The site investigation is to consider the characteristics of the area for their potential to treat and dispose of wastewater. A system design must consider the treatment of wastewater as high a priority as disposal. In the past, the typical approach was to make disposal the first and sometimes only priority as evidenced by the use of seepage pits and deep trenches.

To understand absorption field design requirements, it is absolutely essential that one understands the importance given to adequate treatment of the effluent before complete disposal.

One basic objective is to distribute the effluent over a wide enough area so as to not overload the soil's capacity for adequate treatment. Another basic objective in designing a system is to keep the trench depth as shallow as possible. One advantage of shallow trenches is to promote more evaporation and transpiration of excess water. The fundamental reason for keeping the absorption trenches close to the surface is to provide for better conditions for microbial activity and treatment of the effluent.

CHAPTER I  
CHRISTIAN COUNTY  
ORDINANCE 043-1992

CHRISTIAN COUNTY HEALTH DEPARTMENT  
WASTEWATER TREATMENT SYSTEMS  
AN ORDER REGULATING THE CONSTRUCTION, INSTALLATION  
MAINTENANCE AND USE OF WASTEWATER TREATMENT  
SYSTEMS AND PROVIDING PENALTIES FOR VIOLATIONS THEREOF  
IN THE COUNTY OF CHRISTIAN, STATE OF MISSOURI

Authority: Section 192.300, RSMo 1986. The county commission and county health board of Christian County may make and promulgate orders and ordinances or rules and regulations, respectively as will tend to enhance the public health and prevent the entrance of infectious, contagious, communicable or dangerous diseases into such county, but orders or ordinances and rules or regulations authorized shall not be in conflict with any rules or regulations authorized and made by the Department of Health in accordance with this chapter or by the Department of Social Services under chapter 198 RSMo.

**Section 1: Definitions**

1.1 As used in this ordinance the following words and phrases have the following meanings:

- A. Christian County Health Department Wastewater Systems Construction Standards: The construction standards for construction and renovation of on-site wastewater treatment systems in Christian County. These standards meet or exceed the most current standards of the Missouri Department of Health.
- B. Collection Wastewater Treatment Facilities: Any collection wastewater treatment system, other than those owned by a public government entity such as a municipality, which serves maximum daily flows of greater than 3000 gallons per day.
- C. Continuing Operating Authority: Any person or group of persons accepted by MDNR as continuing authorities in accordance with 10 CSR 20-6.010, (3)(A)(B)(C)(D).
- D. Department: The Christian County Health Department
- E. Detailed Design: The sketch drawing with all calculations and alterations.
- F. Domestic sewage: Wastewater originating primarily from the sanitary conveniences of residences, commercial buildings, factories and institutions, including any wastewater that may have infiltrated the sewer.
- G. Health Officer: The Administrator of the Christian County Health Department or an authorized representative.
- H. MDNR: Missouri Department of Natural Resources.
- I. On-site Wastewater Treatment System: A sewage treatment system, or part of a system, serving a dwelling(s) or other establishment(s) which receives domestic sewage discharges less than three thousand (3,000) gallons per day.

J. Permit: A written authorization issued by the Christian County Health Department which authorizes the property owner to construct, install, or modify the wastewater treatment facilities as set forth in this ordinance.

K. Person: An individual, corporation or other legal entity.

L. Property Owner: The person in whose name legal title to the real estate is recorded.

M. Publicly Owned Sewer System: Any public sewer system owned by a municipality.

N. Sketch: A basic drawing of a system that includes all set back distances, the slope and existing drainage of the ground.

## **Section 2: Permits**

2.1 Any person engaged in the construction or renovation of any wastewater treatment system shall obtain a construction permit from the Christian County Health Department.

2.2 No construction permit shall be issued until the property owner has submitted a complete application, including the required permit fee, to the Christian County Health Department.

2.21 Such applications shall contain the following information:

A. Legal description of the property to the nearest 1/4, 1/4 section.

B. On-site systems - a completed Christian County Site Evaluation Form and sketch for the wastewater treatment system.

C. Systems with a maximum daily flow of less than 3000 gallons per day, a complete Christian County Site Evaluation Form, and detailed design of the proposed system.

D. Systems with a maximum daily flow of greater than 3000 gallons per day, a copy of the construction permit issued by the Missouri Department of Natural Resources, and a copy of the engineering plans as approved by the MDNR.

E. Name, address and signature of the installer

F. Name, address and signature of the property owner, or a legally authorized representative of the owner.

G. Type, design and capacity of the proposed system.

2.3 Such on-site wastewater treatment systems shall be approved as to type, design and capacity by the Christian County Health Department prior to issuance of the construction permit, in accordance with current construction standards of the Christian County Health Department.

2.4 Collection wastewater treatment systems shall be approved as to type, design and capacity by the

MDNR, in accordance with current construction standards of the MDNR. No collection wastewater treatment systems shall be constructed inside nor within 200 feet of the rim of a sinkhole, cave or spring as defined in the construction standards of the Christian County Health Department. Collection wastewater treatment systems that are proposed to discharge to sinkholes must be constructed 200 feet away from the rim of the sinkhole, cave or spring.

- 2.5 The system shall be constructed by an installer or contractor licensed by the Christian County Health Department, except homeowners as stated in Section 3.1.
- 2.6 Any applicant knowingly providing false information on the application shall be subject to termination of the construction permit.
- 2.7 Any construction permit holder shall grant access to the Health Officer upon request, for the purpose of inspection and/or sampling.
- 2.8 Any owner or operator shall grant access to the Health Officer upon request, for the purpose of investigating a complaint or inspection and sampling of an MDNR permitted wastewater treatment system.
- 2.9 No property owner, installer or other person shall discharge waste into a newly constructed or renovated wastewater treatment system until it is inspected and approved for use by the Health Officer.

### **Section 3: License and Registration Program**

- 3.1 Any person engaging in the installation, construction, or renovation of any on-site wastewater treatment system, not for personal use by themselves shall be duly licensed by the Department. A homeowner is not required to be licensed by the Department to install, add to, alter or repair the private wastewater system that serves the homeowner's permanent residence, however, a permit must be obtained. Homeowners installing or repairing their own system must first attend the installer's training provided by the department. All construction and excavation must be done by the homeowner, or the homeowner may contract any part of the construction or excavation to an installer licensed in Christian County. If part of this type of system is contracted to an installer licensed in this county, the installer shall be able to guarantee only those parts of the system. The homeowner is required to meet all other requirements of this ordinance.
- 3.2 Every applicant for license shall demonstrate a thorough knowledge of the Department's minimum standards of construction for on-site wastewater treatment systems.. All licensees are required to attend a training session every 2 years within the county, which will be provided by the Department.
- 3.3 An applicant shall guarantee workmanship and materials on all installations of on-site wastewater treatment systems for one year.
- 3.4 Any licensee failing to comply with any regulations, rules, orders and decisions of the Department relative to the type of on-site wastewater treatment systems installed, constructed or renovated shall be subject to revocation of license or suspension.
- 3.5 Any licensee failing to comply with the stated provisions for inspection of the on-site wastewater

treatment system shall be subject to revocation or suspension.

- 3.6 Any licensee installing, constructing or renovating any on-site wastewater treatment system for which no permit exists shall be subject to revocation or suspension.
- 3.7 The licensee shall provide any and all installation data requested by the Department and shall maintain complete and accurate records of each installation on an on-site wastewater treatment system for a period of not less than three (3) years. The licensee shall provide a copy of the complete record of installation to the builder and/or homeowner.
- 3.8 The licensee shall report promptly to the Department any conditions not in accordance with the permit and shall cease construction of any installation of an on-site wastewater treatment system until approval is obtained.
- 3.9 Operators of collection wastewater treatment systems shall be registered with the Department and shall attend a training course presented by the Department. This course shall be conducted under the auspices of the MDNR.
- 3.10 Professionals conducting site evaluations shall be registered with the Department, and before conducting site evaluations shall attend an evaluation presented by the Department. This evaluation will be conducted under the auspices of a local university's agronomic department, and will include at a minimum, a written examination and a practical examination. This requirement is in addition to the minimum criteria for site evaluations as defined in the construction standards.
- 3.11 Any professional knowingly providing false information on the site evaluation form shall be subject to revocation of their registration.

#### **Section 4: Powers and Authority of Department Officials**

- 4.1 The Health Officer, bearing proper credentials and identification, shall be permitted to enter all properties for the purposes of inspection, observation, measurement, sampling, and testing in accordance with the provisions of this order.

#### **Section 5: Operation of Systems; Inspection and Sampling**

- 5.1 When a publicly owned sanitary sewer is not available within 300 feet, the building sewer shall be connected to an on-site wastewater treatment system in compliance with the provision of this ordinance.
- 5.2 A wastewater treatment system, including collection wastewater treatment facilities, shall not be approved for use until the installation is completed in accordance with the approved plans. Existing collection wastewater treatment facilities shall be inspected by the Department before the owner or operator requests sewer line extensions for new hook-ups from the MDNR. The Health Officer shall be allowed to inspect the work at any state of construction, and in any event, the applicant for the permit shall notify the Health Officer when the work is ready for final inspection and before any underground portions are covered. The inspection shall be made within twenty-four (24) hours of the receipt of notice by the Health Officer.



- 5.3 Building sewer connections to collection wastewater treatment facilities shall not be put into use until the installation is inspected and approved by the Department.
- 5.4 Collection wastewater treatment facilities shall be operated in accordance with all requirements of MDNR and/or the Public Service Commission, and shall not create a nuisance or potential public health hazard.
- 5.5 Collection wastewater treatment facilities shall be inspected and sampled quarterly and as needed by the Department in accordance with any recommendations or requirements of the MDNR.
- 5.6 The Health Officer shall report all inspections and/or sample results to the MDNR and the PSC, as applicable.
- 5.7 The construction, installation and renovation of an on-site wastewater treatment system shall comply with the current construction standards of the Christian County Health Department.
- 5.8 No property owner or operator shall allow domestic wastes to be discharged into a wastewater treatment system that is in violation of this ordinance.
- 5.9 A violation of this ordinance occurs when and if flows from the on-site wastewater treatment system are:
- (a) leaving the owner's property, either on the surface or subsurface,
  - (b) not in compliance with the permit's conditions
  - (c) contributing pollutants to the surface waters or groundwater's, or
  - (d) creating a nuisance, source of excessive odors, or potential public health hazard.
- 5.10 No statement contained in this section shall be construed to interfere with any additional requirements that may be imposed by the Department.

## **Section 6: Fees**

- 6.1 Fees will be collected by the Department for building sewer hook-ups, inspections and the periodic sampling of all systems.
- 6.2 Fees will be collected by the Department for training of installers and site evaluators.

## **Section 7: Penalties**

- 7.1 Any person found to be violating any provision of this ordinance shall be served by the Department with a written notice, via certified mail, or in person, stating the nature of the violation and providing a reasonable time limit for the satisfactory correction thereof. The offender shall, within the period of time stated in such notice, permanently cease all violation.
- 7.2 Any person violating the provisions of this ordinance shall be guilty for each and every violation of misdemeanor, and upon conviction thereof shall be fined not less than two hundred and fifty dollars (\$250.00) nor more than One Thousand Dollars (\$1,000.00) or confined in the county jail for not more than one (1) year, or both. Each day of violation constitutes a new offense.

7.3 Any person violating any of the provisions of this ordinance shall become liable to the Department for any expense, loss, or damage incurred by the Department by reason of such violation.

### **Section 8: Appeals**

8.1 Any person aggrieved by any decision of the County Health Officer may appeal to the Board of Appeals by filing a written application with the County Health Officer within thirty (30) days after being notified of the decision which is the subject of the appeal. The Board of Appeals shall schedule a hearing on appeal, and shall give the person notice of the date of hearing at least ten (10) days prior to the hearing date and give the person reasonable opportunity to be heard. Appeal hearings to the Board of Appeals shall be conducted in accordance with Board of Appeal's adopted rules and procedures.

### **Section 9: Severability**

9.1 If any section, clause or phrase of this regulation is, for any reason, held to be invalid by any court of competent jurisdiction, such decision shall not affect the remaining portions of this ordinance.

CHAPTER II

REQUIREMENTS FOR

SEWER PERMIT

COMPLIANCE

## **CHRISTIAN COUNTY REQUIREMENTS FOR SEWAGE PERMIT COMPLIANCE**

### **SECTION I: Application form**

Construction application forms are available at the Christian County Health Department, Environmental Division located on E. Brick St., Ozark, Missouri.

### **SECTION II: Permit application procedure.**

When submitted the permit application form must have:

A: On-site systems:

1. the soil scientist site evaluation report
2. the installer's sketch
3. the non-refundable application fee

B. Collection wastewater treatment systems:

1. a copy of the construction permit issued by MDNR
2. a complete copy of the engineering plans as approved by MDNR
3. the non-refundable application fee

The applicant must supply all information requested on the form. The applicant must insure that the proposed system is clearly identified in the field. This shall include any tanks, pretreatment components and all lateral lines. If additional information is necessary to properly evaluate the application, the applicant will be notified. Processing the application cannot be continued until requested information is received, and the application fee is paid in full.

### **SECTION III: Application processing**

All permit applications shall be reviewed by and become the property of the Health Department, to determine whether or not it meets the criteria set forth in the ordinance and regulations. Upon reviewing the completed application, including any additional information requested, the Health Department shall review the site within five (5) working days from the date of receipt of the completed application as follows:

- A. Application accepted: If the Health Department determines that the permit application is complete and describes a system that should be approved, the Health Department shall issue pre-construction approval allowing construction of the system. The installer shall be given verbal or written notification of the assigned permit number. It is the installer's responsibility to notify the owner of the permit number. In the event applicant does not receive written or verbal notification within 10 working days of the date of receipt of complete application, it is the applicant's responsibility to contact the department to verify the status of the permit prior to any construction. The system can then be constructed if permit application is approved.
- B. Modification: When the Health Department determines that a system as drawn requires modification,

the department shall issue written or verbal notification to the applicant stating that determination. The written or verbal notification shall include a specific description of the modification(s) necessary to obtain approval of the application. The applicant must submit modified sketch drawings, or other information required before preliminary permit approval will be granted.

- C. Denial: If the Health Department determines that the permit application should be denied, the Health Department shall issue written notification to the applicant stating that determination.

#### **SECTION IV: Construction**

- A. Upon notification of an approved permit number, the applicant may construct the system as designed in the permit application in accordance with the statements, representations and procedures outlined in the application and supporting documents.
- B. If the applicant should discover after beginning construction that the system cannot be constructed in accordance with the approved application, the applicant shall request approval for a modification of the plans set forth in the application. Such a request for modification could involve a modification of the materials and/or procedures specified in the permit application and should specify alternate materials and/or procedures which must meet the criteria of the construction standards. The applicant shall make this request for modification in writing to the Health Department prior to construction of the system. The Health Department shall process the request for modification in the same manner described in the procedures set forth in Section III of these rules. In the event of a minor modification, the installer may proceed with construction and then present the inspector with a revised sketch upon their arrival for the final inspection. Note: Christian County Health Department does not guarantee approval of minor modifications, which might affect the integrity of the system without prior approval.
- C. The applicant shall notify the Health Department at least one business day before final inspection is needed. All notifications must be made to the Health Department office, Monday through Friday between the hours of 8:00 a.m. and 4:30 p.m. Telephone number is 581-8183.

The Health Department will perform a final inspection of the system before it is backfilled to assure compliance with the construction standards. Inspection hours are Monday through Friday, 9:00 A.M. to 4:00 P.M with inspections being scheduled on a first request basis. No inspections will be scheduled on weekends or the following holidays:

New Year's Day	July 4th	Veterans' Day
Martin Luther King Day	Labor Day	Thanksgiving Day
Presidents' Day	Columbus Day	Christmas Day
Memorial Day		

The installer shall notify the Health Department to cancel scheduled inspections if the system will not be completely done at the appointed time. Inspections that are not canceled a minimum of 1 hour before the scheduled time will be assessed an unnecessary trip charge (see fee schedule).

If the applicant shall fail to notify the Health Department before backfilling the system, or if system is backfilled before corrections have been made, the Health Department will order the applicant to uncover the

system to allow inspection. Failure to comply may result in a suspended or revoked permit, and the department may bring an action for injunctive relief in the Circuit Court of Christian County.

#### **SECTION V: Permit duration and renewal**

A permit issued pursuant to this ordinance shall be valid for a period of one year from the date of approval. An applicant may request renewal of a permit for an additional one year period by filing a request for renewal with the Health Department before the date of expiration of the original permit. If the applicant fails to renew the permit by expiration date, the permit shall expire. The applicant must obtain a new permit prior to the beginning or continuing construction of the system. No refund of inspection or processing fee will be refunded on expired permits. Permit renewals will be charged a handling fee. (see fee schedule)

#### **SECTION VI: Permit transfer**

- A. A permit number issued pursuant to the ordinance may be transferred from the original owner to a new owner of the property on which the system is to be constructed. The applicant shall file an application for transfer of the permit with the Health Department. The Health Department shall process the application for transfer in the same manner described in the procedures set forth in Section III of these rules. An additional processing fee will be charged for transfers (See fee schedule).
- B. A permit may be transferred from one licensed installer to another licensed installer as follows:
  - 1. A new permit application must be signed and submitted.
  - 2. A new sketch drawing shall be submitted if the system is to be designed or installed differently than original drawing.
  - 3. An additional processing fee will be charged for transfers. (See fee schedule)

#### **SECTION VII: Permit revocation or suspension**

The Health Department may revoke or suspend a permit before or after construction of a system is completed for any reason necessary to insure full compliance with this ordinance or with any applicable statutes or regulations. The reasons for revocation or suspension may include, but are not limited to the following:

- A. Noncompliance, by the applicant, with the terms of the permit.
- B. Unapproved deviation by the applicant from the design, construction plans or specifications set forth in the complete application and supporting documents.
- C. A determination that the applicant supplied false information in the application and/or supporting documents.
- D. Changed site conditions which would result in violations of the construction standards or the ordinance.

The Health Department shall provide written notification of its decision to revoke or suspend the permit. The notification shall include the reasons for revocation or suspension of the permit and any corrections that could be made to reinstate the permit. If the applicant wishes to appeal this decision, this may be done in accordance with the provisions for appeal as set forth in this ordinance.

**SECTION VIII: Temporary Licensing**

Installer’s holding a current state license may apply for a temporary conventional license one time only. After successful completion of a department provided test, an installer will be granted a temporary conventional license. This license will expire on the next regularly scheduled training date provided by the Christian County Health Department. There will be a fee for temporary licensure.

When a temporary installer’s license expires, the installer will be required to apply for a regular license in the same manner as other installers. This process includes payment of the regular licensing fee and successful completion of a written examination.

**SECTION IX: License Revocation or Suspension**

The Health Department may revoke or suspend an installer’s license upon determination that a violation of Ordinance #043-1992 has occurred. The procedure for suspension or revocation will be as follows:

- First Infraction.....30 day suspension
- Second Infraction.....90 day suspension
- Third Infraction.....1 year revocation
- Fourth Infraction.....Permanent revocation

Upon notification that a violation of the ordinance has occurred, the Health Department will investigate the complaint. If the Health Department determines that a licensed installer has violated any section of this ordinance, the department shall provide written notification, via certified mail, of its decision to revoke or suspend the installer’s license. The notification shall include the reasons for revocation or suspension of the license, and any corrections that must be made to reinstate the license at the end of the penalty time. Any installer served with a suspension or revocation order must retake the appropriate installer’s training course prior to reinstatement.

During the time of the installer’s license suspension or revocation, no new permit applications will be accepted by this department and no construction inspections for final approval will be conducted on systems with permit numbers.

If the applicant wishes to appeal a suspension or revocation decision, it may be done in accordance with the provisions set forth in this ordinance.

The Health Department will maintain a list of installers whose license have been revoked or suspended, including date of suspension or revocation. This list will be available to the public upon request.

## **SECTION X: Fee schedule**

Fees are as follows:

### ***On-site systems***

Residential (new & rehabs)	\$75.00
Commercial (flows greater than 240 gpd)	\$100.00
Commercial (flows less than 240 gpd)	\$75.00
Gray water system	\$50.00
Renewals: (Permits are good for 1 year)	
Unexpired permit	\$5.00
Expired permit	\$75.00
Unnecessary trip charge	\$20.00
Transfer Fee	\$25.00
Tank Leak Test (includes initial & follow up)	\$40.00
Building Sewer Hook-up	\$25.00

### ***Collection wastewater systems***

Construction permit	\$200.00
Inspection/sampling	\$35.00 per trip/test

### ***Wastewater Installer Training***

Installer Training Fee	\$50.00
Temporary License Fee	\$25.00



CHAPTER III

DESIGN

AND

CONSTRUCTION

STANDARDS

# Christian County Onsite Wastewater Standards

*Purpose: This rule establishes minimum construction standards for on-site sewage disposal systems. In accordance with the authority granted in Christian County Ordinance (CCO) 043-1992, this rule establishes the minimum standards and criteria for the design, location, installation, and repair of individual on-site sewage disposal systems to promote the public health and general welfare and to protect the surface and ground waters of Christian County.*

## (1) GENERAL.

**(A) Definitions.** Definitions as set forth in CCO 043-1992, On-Site Sewage Disposal Law shall apply to those terms when used in this rule unless the context clearly requires otherwise or as noted in this subsection. For the purposes of these standards, certain terms or words used here shall be interpreted as follows. The word shall is mandatory and the words should and may are permissive. All distances, unless otherwise specified, shall be measured horizontally:

1. **Administrative authority**—The governing body, Christian County Health Department (CCHD) which has, as authorized by statute, charter or other form of enabling authority, adopted these standards for domestic on-site sewage disposal systems;
2. **Advanced treatment component** - A component of any system that provides additional treatment prior to discharge into the lateral field;
3. **Aeration unit**—Any sewage tank which utilizes the principle of oxidation in the decomposition of sewage by the introduction of air into the sewage;
4. **Alluvium**—Soil parent material which was transported and deposited in a running water setting;
5. **Altered sinkhole** - A sinkhole which has been filled, excavated or otherwise disturbed;
6. **Alternative System**—An individual sewage treatment system employing methods and devices as presented in this rule;
7. **Approved**—Considered acceptable by the administrative authority;
8. **Baffle**—A device installed in a septic tank for proper operation of the tank and to provide maximum retention of solids. This includes vented sanitary tees and submerged pipes in addition to those devices normally called baffles;
9. **Bedrock**—That layer of geologic material which is consolidated;
10. **Bedroom**—Any room within a dwelling that may be used as a sleeping room. The number of bedrooms in a residence as given by owner/contractor will be used

in determining volumes in the sizing of on-site sewage disposal systems;

11. **Black water**—waste carried off by toilets, urinals and kitchen drains;
12. **Bottomland** - The lowest flood plain above a stream channel or river subject to flooding that exhibit alluvial deposits in the soil horizons;
13. **Building sewer** - That part of the drainage system which extends from the end of the building drain and conveys its discharge to the primary treatment device of a sewage treatment system or to the sewer main of a wastewater treatment plant;
14. **Capacity**—The liquid volume of a sewage tank using inside dimensions below the outlet;
15. **Color**—The moist color of the soil based on the Munsell soil color system;
16. **Dispersal and treatment area**—That area of trench or bed bottom which is in direct contact with the trench rock of the soil treatment system, and extending throughout the absorption field. Including manifolds, lateral lines, distribution devices and connecting pipe. (excluding supply lines);
17. **Distribution pipes**—Perforated pipes that are used to distribute sewage tank effluent in a soil treatment system;
18. **Dosing chamber** (or pump pit or wet well)—A tank or separate compartment following the sewage tank which serves as a reservoir for the dosing device;
19. **Dosing device**—A pump, siphon or other device that discharges sewage tank effluent from the dosing chamber to the soil treatment system;
20. **Dwelling**—Any building or place used or intended to be used by human occupants as a residential unit(s);
21. **Effluent**—The liquid discharge of a septic tank or other sewage treatment device;
22. **Environmental Public Health Specialist (EPHS/Sanitarian)**—A person registered as an EPHS/Sanitarian by the Missouri Board of Certification for Environmental Health Professionals or the National Environmental Health Association or employed as an EPHS by the state or local health department;
23. **Equal Distribution**— Devices for dispersing effluent equally to all lateral lines;
  - (a) Gravity distribution includes devices such as distribution boxes, dipper box, and flow splitters;
  - (b) Pressure distribution includes devices such as manifolds, low pressure pipe, subsurface drip irrigation;

24. *Fault* - A fracture or fracture zone along which there has been displacement of the sides relative to one another parallel to the fracture. This provides direct access to the groundwater system;
25. ***Flood Plain***-as defined by the most currently adopted by Christian County FEMA NFIP
26. *Fracture* - A break in bedrock along which no translational movement has taken place;
27. *Gravelless system*-An absorption system recognized by the administrative authority as an acceptable method of subsurface treatment of sewage without the required use of gravel. The following are examples:
- (a) Large diameter, eight inch (8") and ten inch (10") corrugated, perforated plastic pipe, wrapped in a sheath of spun-bonded filter wrap;
  - (b) Chamber system;
  - (c) Drip irrigation; and
  - (d) Polystyrene aggregate absorption system;
28. *Gray water*-all domestic waste not covered in paragraph 11, including bath, lavatory, laundry and sink waste;
29. *Grease trap*-A device designed and installed so as to separate and retain oils and fats from normal wastes while permitting normal sewage or wastes to discharge into the drainage system by gravity;
30. ***Ground absorption sewage treatment and disposal system***-A system that utilizes the soil for the subsurface disposal of partially treated or treated sewage effluent. The following are examples:
- (a) ***Chamber system***-A system that uses an open bottom structure which forms an underground chamber over the soil's infiltrative surface. The wastewater is discharged into the chamber through a central weir, trough or splash plate and is allowed to flow over the infiltrative surface in any direction;
  - (b) ***Standard soil absorption system***-A system that distributes effluent by gravity flow from the septic or other treatment tank and applies effluent to the soil through the use of a seepage trench or bed;
  - (c) ***Dosing soil absorption system***-A system that distributes effluent by a pump or automatic siphon to elevate or distribute effluent to the soil through the use of a seepage trench or bed;
  - (d) ***Drip sub-surface soil absorption system***-A system that distributes effluent through drip lines below the soil surface in a grid pattern (also known as trickle irrigation);
  - (e) ***Pressure distribution system***-A soil absorption system that distributes pressurized effluent equally throughout the absorption field by a **pump and smaller diameter distribution piping with small diameter perforations to distribute effluent;**
31. ***Hazardous waste***-Any waste or combination of wastes, as determined by the Hazardous Waste Commission by rules, which, because of its quantity, concentration, or physical, chemical or infectious characteristics, may cause or significantly contribute to an increase in mortality or an increase in serious irreversible, or incapacitating reversible, illness, or pose a present or potential threat to the health of humans or the environment;
32. ***High ground water***-Zones of soil saturation which include: perched water tables, shallow regional ground water tables or aquifers, or zones that are seasonally, periodically or permanently saturated;
33. ***Highly permeable bedrock formations*** - Bedrock formations that have a high potential for groundwater contamination. Usually these include the Mississippian Burlington-Keokuk, the Elsey-Reeds Springs, Pierson, Compton Formation;
34. ***High-water level***-The highest known flood water elevation of any lake, stream, pond or flowage or the regional flood elevation established by a state or federal agency;
35. ***Holding tank***-A watertight tank for temporary storage of sewage until it can be transported to a point of approved treatment and disposal;
36. ***Horizon***-A layer of soil, approximately parallel to the surface, that has distinct characteristics relative to adjacent layers;  
***Individual sewage treatment system***-A sewage disposal system, serving a dwelling(s) or other establishment(s), which utilizes subsurface soil treatment and disposal;
37. ***Intermittent sand filters***-Intermittent sand filters are beds of granular materials twenty-four to thirty-six inches (24-36") thick underlain by graded gravel and collecting pipe. Waste water is applied intermittently to the surface of the bed through distribution pipes or troughs and the bed is under drained to collect and discharge the final effluent. Uniform distribution is normally obtained by dosing so as to flood the entire surface of the bed. Filters may be designed to provide free access (open filters) or may be buried in the ground (buried filters or subsurface sand filters);
38. ***Intermittent stream*** - A stream which flows only during wet seasons;
39. ***Karst*** - A term used to indicate a terrain of limestone on and in which have developed sinkholes, caves, subterranean drainage and other features typically formed by solution of limestone;
40. ***Limiting layer*** - Bedrock or limiting soil horizon that significantly restricts water and air movement

- creating unsuitable conditions within the horizon for wastewater treatment and disposal;
41. *Limitation ratings* - A rating to indicate a site's limitations for an on-site wastewater system;
  42. *Losing stream* - A stream in a Karst area that enters an underground water course;
  43. *Low permeability bedrock* - With regard to bedrock, a bedrock having very few cracks or crevices and having a vertical permeability less than one inch (1") in twenty-four (24) hours shall be considered low permeability bedrock. With regard to soils, a soil horizon or layer having a vertical permeability less than one inch (1") in twenty-four (24) hours shall be considered impermeable;
  44. *Matrix color*—The dominant color of a soil material;
  45. **Modified standard system - A standard absorption system that has been modified to overcome selected soil and site limitations such as:**
    - 1) **Shallow placement**
    - 2) **Sandlined trenches**
    - 3) **Pump distribution;**
  46. *Mottling*—Spots or splotches of color interspersed in the dominant (or matrix color) of a soil material. Mottles may be of a wide variety of colors;
  47. *Mound system*—A system where the soil treatment area is built above the ground to overcome limits imposed by proximity to water table or bedrock or by rapidly or slowly permeable soils;
  48. **Non-ground absorption sewage disposal system—A facility for waste treatment designed not to discharge to the soil, land surface, or surface waters, including, but not limited to, incinerating toilets, mechanical toilets, composting toilets and recycling systems;**
  49. *Other establishment*—Any public or private structure other than a dwelling which generates sewage;
  50. **OWTS-Onsite Wastewater Treatment System;**
  51. *Pan*—A soil horizon compacted, hard or very high in clay content. These horizons are usually very slowly permeable. Common pans in Missouri are claypans and fragipans;
  52. *Peat biofilter system* - System utilizing peat in modules as a medium to purify effluent from a septic tank;
  53. **Perched water table—A saturated zone above and separated from the water table by a horizon which is unsaturated;**
  54. *Perennial stream* - A stream that flows all year;
  55. **Permeability—The ease with which liquids and gases move within the soil or rock;**
  56. *Photo lineament* - A line or linear feature shown on an aerial photograph that is structurally controlled. It is aerial photo evidence of joints and fractures in the bedrock;
  57. *Polystyrene Aggregate Absorption Field* - One twelve inch (12") diameter bundle containing a four inch (4") diameter corrugated pipe in synthetic gravel made of polystyrene aggregate encased in a netting;
  58. **Privy—An outhouse or structure used for receiving human excrement in a container or vault beneath the structure;**
  59. **Professional engineer - A civil engineer holding a current license to practice from the Missouri Board for Architects, Professional Engineers, Land Surveyors, and Landscape Architects having a background in soils, wastewater, and Karst terrain.**
  60. *Registered geologist*—A person who meets the requirements of Chapter 256, RSMo;
  61. *Renovation* - Any addition, alteration, repair, modification, or replacement of any part of an onsite wastewater treatment system or building sewer connection except uncovering the septic tank or pump chamber for solids removal;
  62. *Replacement sites* - An area on a property with an existing system in which a new system can be installed;
  63. **Restrictive horizon—A soil horizon that is capable of perching ground water or sewage effluent and that is brittle and strongly compacted or strongly cemented with iron, aluminum, silica, organic matter or other compounds. Restrictive horizons may occur as fragipans, iron pans or organic pans and are recognized by their resistance in excavation or in use of a soil auger;**
  64. *Rock fragments*—The percentage by volume of rock fragments in a soil that are greater than two millimeters (2 mm) in diameter or retained on a No. 10 sieve which may include, but is not restricted to, chert, sandstone, shale, limestone or dolomite; The amount of rock fragments in a soil is of a concern in areas of residual soils overlying highly permeable bedrock;
  65. **Sanitarian—A person registered either as a sanitarian or environmental health specialist by the National Environmental Health Association or the Missouri Board of Certification for Environmental Health Specialist or employed as a sanitarian or environmental health specialist by the administrative authority;**
  66. *Seasonal high water table (SHWT)* - The highest elevation in the soil where all voids are filled with water, as evidenced by presence of water or soil mottling or other information. This includes perched water tables and zones of saturation for long periods of time;
  67. *Septage*—Those solids and liquids removed during periodic maintenance of a septic or aeration unit tank or those solids and liquids removed from a holding tank;
  68. *Septic tank*—An approved watertight, covered receptacle designed and constructed to receive the

- discharge of sewage from a building sewer, separate solids from liquid, digest organic matter, store liquids through a period of detention and allow the clarified liquids to discharge to a soil treatment system;
69. *Setback*—A separation distance measured horizontally;
  70. *Severe geological limitations* - Site specific geologic conditions which are indicative of rapid recharge of an aquifer and likely groundwater contamination;
  71. *Sewage*—Any water-carried domestic waste, exclusive of footings and roof drainage. Domestic waste includes, but is not limited to, liquid waste produced by bathing, laundry, culinary operations, liquid wastes from toilets and floor drains and specifically excludes animal waste and commercial process water. Also known as wastewater;
  72. *Sewage flow*—Flow as determined by measurement of actual water use or, if actual measurements are unavailable, as estimated by the best available data provided by Table II of these standards;
  73. *Significant groundwater contamination potential*—Any condition which would cause or indicate rapid recharge of an aquifer;
  74. *Single dwelling wastewater stabilization pond* -A sealed earthen basin which uses the natural unaided biological processes to stabilize wastewater used on larger lots (also known as a sewage lagoon);
  75. *Sinkhole* - Any natural depression in the surface of the ground, with or without collapse of adjacent rock that can provide a means through which surface water can come into contact with subsurface water. Sinkhole depressions may be gradual or abrupt; they may or may not have a well defined eye. While most sinkholes can be defined as the area with a “closed depression contour”, some sinkholes such as those located on sides of hills may not. All sinkholes provide discreet points of recharge to groundwater;
  76. *Sinkhole cluster area* - An area containing 2 or more sinkholes located in close proximity, generally interconnected by groundwater conduits. They may also be connected by surface drainage;
  77. *Sinkhole eye* - A visible opening, cavity, or cave generally in the bottom of a sinkhole, sometimes referred to as a swallow hole;
  78. *Sinkhole flooding area* - The area inundated by runoff from a storm with an annual exceedance probability of 1% and a duration of 24 hours;
  79. *Sinkhole floor* - The nearly level to undulating landscape position at the bottom of the sinkhole characterized by alluvial and/or colluvial soil deposits;
  80. *Sinkhole overflow* - Low point on the sinkhole rim. This is the spill over point if the sinkhole fills with water during a heavy rain period;
  81. *Sinkhole rim* - The closest break in elevation above the sinkhole floor, usually the sinkhole overflow point;
  82. *Sinkhole watershed* - The ground surface area that provides drainage to the sinkhole. This area extends beyond the sinkhole depression, and generally crosses property boundaries;
  83. *Site*—The area bounded by the dimensions required for the proper location of the soil treatment system;
  84. *Slope*—The ratio of vertical rise or fall to horizontal distance;
  85. *Soil*—The naturally occurring, unconsolidated mineral or organic material of the land surface developed from rock or other parent material and consisting of sand, silt and clay -sized particles and variable amounts of organic materials;
  86. *Soil saturation*—The condition that occurs when all the pores in a soil are filled with water;
  87. *Soil scientist*—An individual who has a minimum of fifteen (15) semester credit hours of soils course work including a minimum of three (3) hours in the area of soil morphology and interpretations, and is currently licensed by the state of Missouri;
  88. *Soil textural classification*—Soil particle sizes or textures specified in this rule refer to the soil textural classification in the *Soil Survey Manual Handbook No. 18*, U.S. Department of Agriculture, 1993;
  89. *Soil treatment area* - That area of trench or bed bottom which is in direct contact with the trench rock or other approved materials of the soil treatment system and extending throughout the absorption field;
  90. *Soil treatment system*—A system where sewage tank effluent is treated and disposed of below ground surface by filtration and percolation through the soil. It includes those systems commonly known as seepage bed, trench, drainfield, disposal field and includes mound and low pressure pipe systems;
  91. *Springs* - A place where water flows naturally from rock or soil upon the land or into a body of water. Springs may be perennial and flow year round or seasonal;
  92. *Standard system*—An individual sewage treatment system employing a building sewer, septic tank, lateral trenches, drainfield or leach field;
  93. *Toilet waste*—Fecal matter, urine, toilet paper and any water used for flushing;
  94. *Trench rock*—Clean rock, washed creek gravel or similar insoluble, durable and decay-resistant material free from dust, sand, silt or clay. The size shall range from one inch to two and one-half inches (1"–2 1/2"). If limestone, dolomite or other crushed white rock is used, it shall be washed and be a minimum size of one and one-half inches (1 1/2");
  95. *Terminal Sinkhole* - The lowest sinkhole in a sinkhole cluster to which any surface water

overflowing from other sinkholes in the cluster will flow;

96. *Valve box*—Any device which can stop sewage tank effluent from flowing to a portion of the soil treatment area. This includes, but is not limited to, caps or plugs on distribution or drop box outlets, divider boards, butterfly valves, gate valves or other mechanisms;
97. *Wastewater*—same as sewage as defined in paragraph (1) (A) 70. of this rule;
98. *Virgin Sinkhole* - A sinkhole which has never been altered or disturbed;
99. *Watertight*—Constructed so that no water can get in or out below the level of the outlet.

**(B) Applicability.** For these standards, onsite wastewater treatment and disposal system means all equipment and devices necessary for proper conduction, collection, storage, treatment, and disposal of wastewater from a dwelling or other facility producing wastewater flows of three thousand (3,000) gallons per day, or less. Included within the scope of this definition, but not limited to, are building sewers, septic tanks, subsurface absorption systems, mound systems, intermittent sand filters, gravelless systems, single family wastewater stabilization ponds, biofilter systems, aeration unit wastewater treatment systems.

**Commercial or industrial facilities, developers of subdivisions and recreational developments must first contact the Department of Natural Resources concerning compliance with the Missouri Clean Water Law and Regulations before applying for any approvals or permits under this rule.**

**(C) Responsibilities.**

1. The design, construction, operation and maintenance of OWTS, whether septic tank systems or alternative systems, shall be the responsibility of the designer, owner, developer, installer or user of the system.
2. Actions of representatives of the CCHD engaged in the evaluation and determination of measures required to effect compliance with the provisions of this rule shall in no way be taken as a guarantee or warranty that sewage treatment and disposal systems approved and permitted will function in a satisfactory manner for any given period of time. Due to the development of clogging mats, which adversely impact the life expectancy of normally functioning ground absorption OWTS and variables influencing system function which are beyond the scope of this rule, no guarantee or warranty is implied or given that a sewage treatment and disposal system will function in a satisfactory manner for any specific period of time.
3. **Prior to the issuance of a permit to install or effect repair of an OWTS as regulated by Christian County Onsite Wastewater Ordinance #043-1992, plans and**

**specifications shall be required for review. Approval by the administrative authority shall be required for:**

- (a) **Plans for absorption field showing the following:**
  - i) **Field locations with slope(s) indicated or with contour lines based on field measurement. If field areas are essentially flat or of uniform grade, spot elevations will be required for alternate systems;**
  - ii) **Field layout, length, spacing, connection, pipe sizes and cleanout details, invert elevations of flow distribution devices and laterals, valves and appurtenances;**
  - iii) **Trench plan and profile drawings and flow distribution device details;**
  - iv) **Location and design of associated surface and groundwater drainage systems;**
  - v) **Name, address and telephone number of the person(s) drafting the plans; and**
  - vi) **Any other information required by the administrative authority; and**
- b) **Alternative systems whether or not specifically described in this rule.**

4. **The entire sanitary sewage system shall be on property owned or controlled by the person owning or controlling the system. Necessary easements shall be obtained permitting the use and unlimited access for inspection and maintenance of all portions of the system to which the owner and operator do not hold undisputed title. Easements shall remain valid as long as the system is required and shall be recorded with the county recorder of deeds.**

**(D) Minimum Setback Distances.** All OWTS shall be located in accordance with the distances shown in **Table 1.**

**(E) Sewage Flow Rates.** In determining the volume of sewage from single family dwellings, the minimum flow rate shall be one hundred twenty (120) gallons per day per bedroom. The minimum volume of sewage shall be two hundred forty (240) gallons per day. For residential each additional bedroom above (2) bedrooms shall increase the volume of sewage by one hundred twenty (120) gallons per day. When the occupancy of a single family dwelling exceeds two (2) persons per bedroom, the volume of sewage shall be determined by the maximum occupancy at a rate of sixty (60) gallons per person per day. Caution: this calculation can be used only when the number of persons in the single family dwelling is known.

1. For housing developments other than a single family residence and other establishments, Table II shall be used to estimate the sewage flow rate. Actual metered flow rate may be used instead of sewage flow rates. If metered flow rates are used, documentation from the public water supply serving an existing facility in similar locations shall be provided to the department.

**Table 1-Minimum Setback Distances<sup>8</sup>**

Minimum Distance in Feet From	Sewage Tank <sup>1,10</sup>	Disposal Area <sup>2,10</sup>	Lagoons <sup>4</sup>
Private water supply well <sup>1,3</sup>	50	100	<b>100</b>
Public water supply <sup>8c</sup>	300	300	<b>300</b>
Abandoned well - Plugged in accordance with requirements	50	100	<b>100</b>
<b>Cistern</b>	<b>25</b>	<b>25</b>	<b>25</b>
Perennial or Intermittent stream, lake or impoundment*	50	50	<b>50</b>
Top of slope of embankments or cuts of 2 feet (2') or more vertical height including open ditch	25	25	<b>25</b>
Property lines	10	10*	<b>75</b>
Building foundation	5	15	<b>100</b>
Basement	5	25	<b>100</b>
Basement - system down slope from floor of basement	5	15	-----
Swimming Pool	25	50	<b>50<sup>4</sup></b>
Water line under pressure	10	10	<b>10</b>
Suction line under pressure	50	100	<b>100</b>
Upslope interceptor drains	-	10	<b>10</b>
<b>Edge of surficial sink holes</b>	<b>50</b>	<b>100</b>	<b>100</b>
Other soil absorption system except repair area	-	20	<b>20</b>
Bottomland	No system		
Ground source heat pump system - horizontal	25	25	<b>25<sup>4</sup></b>
Ground source heat pump system - vertical	50	150	<b>150<sup>5</sup></b>
Identifiable faults, photo lineaments or fracture trend	100	100	<b>100</b>
Caves, springs, sinkhole rim <sup>8,9</sup>	100	100	<b>100</b>

\* **Recommend twenty-five feet (25') of downslope property line initially.**

<sup>1.</sup> **Includes sewage tanks, pump tanks, intermittent sand filters, dosing chambers, aeration tanks and any other compartment which has the capacity to hold sewage or effluent. Does not include distribution devices.**

<sup>2.</sup> **Includes all systems (sand filter, wetland and the like) except wastewater stabilization ponds.**

<sup>3.</sup> **Unplugged abandoned wells or wells with less than eighty feet (< 80') of casing depth shall have one-hundred-fifty feet (150') minimum distance from all above.**

<sup>4.</sup> **Setback for lagoon to residence it serves, setback to neighboring residence 200 feet.**

<sup>5.</sup> **To be measured downslope from feature.**

<sup>6.</sup> **Applicable if the system is upslope from features.**

<sup>7.</sup> Systems of treatment and disposal on new construction sites which do not meet these minimum setbacks and/or with severe setback limitations may be used on lots platted before May 1, 1992 provided:

- a) The site evaluator specifically addresses the setback problem in the site evaluation report and presents justification for the utilization of the proposed system on a site that fails to meet the minimum setback requirements.
- b) The system designer submits a design plan to the CCHD detailing how the system can be designed and placed so as to address the minimum setback limitation.
- c) If the setback to public water wells that are identified by MDNR cannot be met, for sites that have been platted prior to the effective dates of these standards, the setback may be considered for reduction to the 100'

allowed by state law, provided step a) and step b) are followed.

<sup>8.</sup> The setbacks for caves and springs are measured up gradient of the known or observed "mouth" or origin of each respective feature.

<sup>9.</sup> One of the following methods will be used in determining sinkhole setback distances:

- a) The sinkhole rim will be used when well defined;
- b) On sinkholes without a well-defined rim the sinkhole overflow elevation line may be used for determining the required setbacks;
- c) When a) or b) above cannot be determined, computation of the flooding elevation of the sinkhole shall be submitted to the department. The procedures for this computation are found in the Appendix of these standards. In this case, the setback shall be 100 feet away from the sinkhole flooding elevation;
- d) In no case may any part of a system be closer than 100 feet from any portion of a sinkhole floor;

<sup>10.</sup> Buildings, driveways or any permanent structure/feature/patio shall not be constructed on top of or within 5 feet of a sewage tank or disposal area

**(F) Replacement sites:**

Replacement sites which cannot meet these minimum setback distances for any systems in the standards, shall be placed as far from the setback feature as possible in the appropriate direction and may require an alternative system and or a pretreatment system if the site evaluator or the department believes one is necessary due to the setback limitations. A written application for a setback variance shall be submitted to the department with permit application, and shall include the following:

1. An explicit description explaining why the required setback distance cannot be complied with;
2. Potential impact, if any, on adjacent property owners and the names and mailing address of these property owners;
3. All adjacent property owners shall be notified in writing by the department. The party requesting the setback variance shall be responsible for supplying the names and addresses of all adjacent property owners to the department. Adjacent property owners shall be allowed thirty (30) days from the date of written notification to contact the department to express comments concerning the consideration of granting a setback variance. Cost of notification shall be the responsibility of the applicant for the variance.
4. The above information shall be documented on variance request form (adjacent landowner) provided by the Christian County Health Department.
5. Easements: In the event there is not sufficient area for any type of an approved system to be constructed on the homesite, an easement to a consenting adjacent landowner's

property may be granted. Such easements will be recorded in the County Recorder's Office and subject to department approval prior to preliminary approval of the permit application.

6. **Deficient replacement sites** due to severe soil conditions that would not be permitted for new construction sites may be approved using non-conventional methods if the following conditions are met:
  - a) The site evaluator states that it appears to be feasible to install an on-site wastewater system in an attempt to avoid a holding tank. The site evaluator shall specify a system and present justification of the non-conventional system.
  - b) The homeowner signs a deficient replacement site acknowledgment form stating that the site would not be permitted for a new construction site and is receiving a permit for a replacement site in order to avoid the expense of maintaining a holding tank.
  - c) The department may require that an advanced treatment component be included in this system.
  - d) The deficient replacement site acknowledgment form must be recorded in the County Recorder's Office. Permit application approval will be withheld until a copy of the recorder's document is submitted to the department.

**See Table II next page**



**TABLE II—Quantities of Domestic Sewage Flows**

**Type of Establishment<sup>1</sup>**

**Flow**

**Residential Units**

	(gallons per day per unit unless otherwise indicated)
Single Family Dwelling	120/bedroom
Multiple Family Dwelling (with laundry <b>capabilities</b> )	120/bedroom
Multiple Family Dwelling (without laundry <b>capabilities cottages</b> )	95/bedroom

50/person  
**(In excess of 2 persons/bedroom)**

**Commercial Facilities**

Transportation terminals (airports, bus stops, railroad stations and the like)	5/passenger
Laundromats	580/machine
Beauty Shops (Style Shops)	125/chair
Bowling Lanes	50/lane
Business (other than those listed elsewhere in this table)	25/employee
Factories (exclusive of industrial waste)	25/person/shift
add for showers	10/person/shift
Motels/Hotels	120/room
with cooking facilities	175/person
Offices	25/person/shift
Service Stations (with or without food)	250/toilet or urinal
24-hour Service Stations	325/toilet
Theaters: Movies	5/seat
Drive-in	15/vehicle space
Public parks (toilets/urinals only)	5/user
Public parks with bath house	25/user

**Camps**

Summer Camps without kitchen	25/person
<b>Summer Camps with kitchen</b>	60/person
Campgrounds—with Comfort Station (without water and sewer hookups)	100/campsites
Travel Trailer/Recreational Vehicle Park (with water and sewer hookups)	120/space ----

**Assembly & Mercantile**

Retail Stores	120/1000 sq. ft. of retail sales area
Stadium, Auditorium,	5/seat
Swimming Pools, Spas, and Bathhouses	10/person
Churches (Not including a Kitchen, Food Service Facility, Day Care or Camp)	3/seat ----
Churches (With a Kitchen but not including a Food Service Facility, Day Care or Camp)	5/seat ----
Country Club not including food prep or dining	20/member

**Food or Drink Establishment\***

Bar (no tap/no food preparation)	5/seat
Bar with tap (no food preparation)	20 /seat
Restaurants	40/seat or.
(per sq. ft. of dining area whichever is greater)	40/15 sq. ft
24-hour Restaurant	75/seat
Food Stands	
1) per 100 square feet of food stand floor space	50 gal.
2) add per food employee	25 gal.
Other food service facilities	5/meal

**Continued**  
**Type of Establishment<sup>1</sup>**

**Flow**

Meat Markets	
1) per 100 square feet of market floor space	50 gal.
2) add per market employee	25 gal.
<b>Institutional**</b>	
Hospitals (includes laundry)	300/bed
Day Care Facilities	15/person
Residential Care Facilities	60/person
Rest Homes and Nursing Homes	
with laundry	120/bed
without laundry	60/bed
Day Schools with cafeteria, gym, and showers	15/student/staff
with cafeteria only	12/student/staff
with neither cafeteria nor showers	10/student/staff
Boarding Schools	60/person

<sup>1</sup> Establishments with flows greater than three thousand gallons per day (3,000 gpd) shall be regulated under Chapter 644, RSMo, administered by the Missouri Department of Natural Resources.

\* Establishments processing food may be required to provide grease interceptors in an accessible location prior to the sewage treatment system.

\*\* These figures do not include shift workers

Gray water/black water systems. Separate systems may be used for gray water and black water systems. Forty percent (40%) of the average daily waste flow shall be used for black water. The remaining sixty (60%) of the average daily waste flow shall be considered gray water. Septic tank sizes for black water systems are as required in these standards. Minimum size gray water tanks shall be five hundred gallons (500 gals.). Gray water connections to the building sewer line require the entire system be brought up to standards if the connection is for non-permitted systems and made outside the building foundation. **If technically possible, the two systems should not be directly up-slope of each other. If this is not possible the black water system should be up-slope of the gray water system. Replacement sites may utilize a gray water system exclusively for the clothes washer.**

1. **Other establishments. For establishments or housing developments other than a single family residence, either Table II shall be used to estimate the sewage flow rate or actual measured flow rate for existing establishments may be used, when replacing its own system. Values for estimated sewage flow for establishments having food service operations shall be increased by a factor of one and one-half (1.5) to compensate for the high organic strength.**
  - a) The grease trap shall conform to Plumbing & Drainage Institute Standard PDI-G101 or equivalent;
  - b) The grease trap shall be plumbed to receive all wastes associated with food handling and no toilet wastes;
  - c) The grease trap liquid capacity shall be sufficient to provide for at least five gallons (5 gals.) of storage per meal served per day, at least two-thirds (2/3) of the required septic tank liquid capacity, or a capacity as determined in accordance with the following:  
 $LC = D \times GL \times ST \times HR / 2 \times LF$  where  
 LC = grease trap liquid capacity (gallons)  
 D = number of seats in dining area  
 GL = gallons of wastewater per meal (1.5 single-service; 2.5 full-service)  
 ST = storage capacity factor = 2.5  
 HR = number of hours open  
 LF = loading factor =  
     1.25 interstate highway  
     1.0 other highways and recreational areas  
     0.8 secondary roads);
  - d) Two (2) or more chambers must be provided, with total length-to-width ratio at least two to one (2:1). Chamber opening and outlet sanitary tee must extend down at least fifty percent (50%) of the liquid depth;
  - e) Access manholes, with a minimum diameter of twenty-four inches (24"), shall be provided over each chamber and sanitary tee. The access manholes shall extend at least to finished grade and be designed and maintained to prevent surface water infiltration. The manholes shall also have readily removable covers to facilitate inspection and grease removal; and
2. Grease traps shall be required at food service facilities, meat markets and other places of business where the accumulation of grease or oils can cause premature failure of a soil absorption system. The following design criteria shall be met:
  - a) The grease trap shall conform to Plumbing & Drainage Institute Standard PDI-G101 or equivalent;
  - b) The grease trap shall be plumbed to receive all wastes associated with food handling and no toilet wastes;
  - c) The grease trap liquid capacity shall be sufficient to provide for at least five gallons (5 gals.) of storage per meal served per day, at least two-thirds (2/3) of the required septic tank liquid

- f) Where it has been demonstrated that specially designed grease interceptors will provide improved performance, the grease trap liquid capacity may be reduced by up to fifty percent (50%).
2. Population to be served. Unless satisfactory justification can be given for using lower per unit occupancies, the figures in Table 2B shall be used in determining the population for which to design the sewage works;

**Table 2B**

	<b>Persons/Unit</b>
Residences	3.7
Apartments or Condominiums	
(1 bedroom)	2.0
(2 bedroom)	3.0
(3 bedroom)	3.7
Mobile Homes	3.0-3.7
Camper trailers without sewer hookup	2.5
Camper trailers with sewer hookup	3.0
Motel/Hotels	3.0

2. Reduction in sewage flow. Reductions in design sewage flow rates may be allowed on a case- by-case basis depending upon water conservation plans.

3. Gray water/black water systems. Separate systems may be used for gray water and black water systems. Forty percent (40%) of the average daily waste flow shall be used for black water. The remaining sixty (60%) of the average daily waste flow shall be considered gray water. Septic tank size for black water systems are as required in these standards. Minimum size gray water tank shall be five hundred gallons (500 gals.). Gray water connections to the building sewer line, requires the entire system be brought up to standards if the connection is for non-permitted systems and made outside the building foundation. If technically possible, the two systems should not be directly up-slope of each other. If this is not possible the black water system should be up-slope of the gray water system. Replacement sites may utilize a gray water system exclusively for the clothes washer.

3. Reduction in sewage flow. Reductions in design sewage flow rates may be allowed by the administrative authority on a case-by-case basis depending upon water conservation plans. Sewage flow rates may be reduced up to forty percent (40%) for gray water systems where the toilet wastes are discharged to a holding tank and disposed of off-site or where waterless toilets are utilized.

**(2) SITE EVALUATION**

**(A) Preliminary Soils Information**

The Christian County Soil Survey available from the USDA-SCS can be used to gather preliminary soils data before the actual site evaluation is conducted. The information in the soils survey is not site specific and can NOT be used in lieu of the actual site evaluation.

**(B) Site Evaluation Procedures**

All site evaluations shall be submitted on the standard form-

**1. Soil Morphology**

The soil morphology evaluation is the only site evaluation method approved in Christian County. This evaluation shall comply with section (9) and be conducted by a professional soil scientist unless a civil engineer, registered geologist or EPHS has had special training and field experience to determine the required soil characteristics and this professional must be registered with the Missouri Department of Health and Senior Services and CCHD per section 3.10 of the Christian County Wastewater Ordinance

**2. Soil Pit**

A minimum of one soil pit shall be dug for each represented soil in the lateral field area. Soil pits shall be dug to a minimum depth of forty-eight inches (48") or as required to determine the significant soil characteristics. More specific information regarding procedures for soils evaluation is in Chapter 9, Site Evaluation.

**(3) BUILDING SEWERS**

Building sewers used to conduct wastewater from a building to an on-site wastewater treatment and disposal system shall be constructed of material meeting the minimum requirements of American Society for Testing and Materials (ASTM) Standards and listed by that agency for such use. Suitable materials meeting ASTM standards include: Acrylonitrile, butadiene styrene (ABS), cast iron pipe, concrete pipe, copper or copper-alloy tubing, polyvinyl chloride (PVC) or vitrified clay pipe. Although listed by ASTM, asbestos cement pipe will not be accepted due to potential health hazards to installers. Building sewer specifications are as follows:

1. Size: Building sewers shall not be less than four inches (4") in diameter;
2. Slope: Building sewers shall be laid to the following minimum slope:
  - a) Four-inch (4") sewer—twelve inches (12") per one hundred feet (100'); and
  - b) Six-inch (6") sewer—eight inches (8") per one hundred feet (100');

3. Cleanouts: A cleanout shall be provided at least every one hundred feet (100') and at every change in direction or slope if the change exceeds forty-five degrees (45°). A cleanout shall be provided between house and tank; and
4. Connection to sewage tank: The pipe going into and out of the sewage tank shall be schedule 40 PVC, cast iron or equivalent and shall extend a minimum of five feet (5') beyond the outlet of the tank providing that **no more** than two feet (2') of pipe **spans across** the excavation hole. **If the pipe spans more than 2', the pipe shall be bedded with 1 ½ to 3" crushed gravel down to the bottom of the excavation hole.** There shall be a minimum of 2' of earth dam between the excavation hole for the tank and the absorption trench;
5. The pipe entering and exiting the septic tank shall be laid with the lettering/numbers up so they are visible for inspection;
6. Building sewers shall not be located in a common trench with or located closer than ten feet (10') horizontally or two feet (2') vertically below a pressure or suction water line. Building sewers may not be placed above a pressure or suction water line in any case;
7. Building sewer lines, if not covered with a minimum of 6" of backfill, must be encased in a larger size pipe of the same strength;
8. The pipe between the **tank excavation hole** and the pump chamber or the absorption system shall be a minimum of five feet (5') in length and four-inch (4") inside diameter and equivalent to the pipe used for the building sewer as set forth in these standards. The pipe shall have a minimum fall of not less than one-eighth inch (1/8") per foot. All joints shall be of watertight construction. Pipe on extreme slopes shall be buried or insulated in the same manner as building sewers;
9. The pipe between a pump chamber and the absorption field shall be a minimum of schedule 40 and shall be sized accordingly with the pump's capacity;
10. Building sewers laid under graveled or paved traffic areas, including drives, shall either be encased in metal conduit, or shall be bedded with a minimum of 4" of cleaned crushed rock, not less than ½" or greater than 1" in size, on all sides of the pipe; or shall be cast iron or ductile iron.

#### **(4) SEWAGE TANKS**

**(A) General.** All liquid waste and wash water with the following exceptions shall discharge into the sewage tank. Roof, garage, footing, surface water, drainage, cooling water discharges and hazardous wastes shall be excluded from the sewage tank. Backwash from water softeners and swimming pool filtration systems may be excluded from the sewage tank. In such event of excluding swimming pool filter backwash, the Department of Natural Resources shall be contacted for applicability of a discharge permit. All sewage tank effluent shall be discharged to a soil absorption system that is designed

to retain the effluent upon the property from which it originated. All tanks regardless of material or method of construction shall:

1. Be watertight and designed and constructed to withstand all lateral earth pressures under saturated soil conditions with the tank empty;
2. Be designed and constructed to withstand a minimum of two feet (2') of saturated earth cover above the tank top; and
3. Not be subject to excessive corrosion or decay. **The tank shall be thoroughly coated inside and out with a bituminous or other suitable coating. Any damage to the bituminous coating shall be repaired by recoating;**
4. Plastic or fiberglass tanks shall be bedded and backfilled in accordance with the manufacturer's instructions. The maximum size of bedding material shall be 3/4" diameter. No plastic or fiberglass tank shall be installed in areas with shallow water tables or shallow bedrock. Plastic or fiberglass tanks shall be properly anchored to prevent flotation.

**(B) Septic Tanks.** Septic tanks, regardless of material or method of construction, shall conform to the following criteria:

1. The liquid depth of any septic tank or its compartment shall **be not less than thirty-six inches (36")**. A liquid depth greater than six and one-half feet (6 1/2') shall not be considered in determining tank capacity;
2. No tank or compartment shall have an inside horizontal dimension less than twenty-four inches (24");
3. **Inlet and outlet connections of the tank shall be protected by baffles or sanitary tees as defined in paragraph (4) (B) 6 of this rule;**
4. The space in the tank between the liquid surface and the top of the inlet and outlet baffles shall not be less than twenty percent (20%) of the total required capacity, except that in horizontal cylindrical tanks, this space shall be not less than fifteen percent (15%) of the total required liquid capacity;
5. Inlet and outlet baffles shall be constructed of acid-resistant concrete, acid-resistant fiberglass or plastic; additionally, plastic sanitary tees shall be used for the inlet and outlet for the sewage tank when baffles are not in place;
6. Sanitary tees shall be affixed to the inlet or outlet pipes with a permanent waterproof adhesive. Baffles shall be integrally cast with the tank, affixed with a permanent waterproof adhesive or with stainless steel connectors top and bottom;
7. The inlet baffle shall extend at least six inches (6") but no more than twenty percent (20%) of the total inlet and outlet devices;
8. The outlet baffle and the baffles between compartments shall extend below the liquid surface a distance equal to forty percent (40%) of the liquid depth except that the penetration of the indicated baffles or sanitary tees for

horizontal cylindrical tanks shall be thirty five percent (35%) of the total liquid depth. They also shall extend above the liquid surface as required in paragraph (4) (B) 4 of this rule. In no case shall they extend less than six inches (6") above the liquid surface;

9. There shall be at least one inch between the underside of the top of the tank and the highest point of inlet and outlet devices;

10. **The inlets and outlets of tanks are encouraged to be fitted with penetration seals during the manufacturing process that meet ASTM C-923 or equal, and applicable to septic tanks when cast in place. Examples of approved seals are:**

- **A-Lok**
- **Blackthorn**
- **Press-Seal**
- **PolyLok**

11. The inlet shall be not less than three inches (3") above the outlet;

12. The inlet and outlet shall be located opposite each other along the axis of maximum dimension. The horizontal distance between the nearest points of the inlet and outlet devices shall be at least four feet (4');

13. Sanitary tees shall be at least four inches (4") in diameter. Inlet baffles shall be no less than six inches (6") or no more than twelve inches (12") measured from the end of the inlet pipe to the nearest point on the baffle. Outlet baffles shall be six inches (6") measured from beginning of the outlet pipe to the nearest point on the baffle; Access to the septic tank shall be as follows:

a) **Manholes. Access shall be provided over both the inlet and outlet devices and to each tank compartment by means of either a removable cover or a manhole. Where the top of the tank is located more than eighteen inches (18") below the finished grade, manholes and inspection holes shall extend to approximately eight inches (8") below the finished grade. The extension can be made using a riser of approved material and fitted with tight covers of heavy metal or concrete. Proper attention must be given to the accident hazard involved when manholes are extended close to the ground surface. Manhole risers are not required when the top of the tank is within eighteen inches (18") of final grade. All manhole openings must be provided with a substantial, fitted, water-tight cover of concrete, cast iron or other approved material. All manhole covers which terminate below grade shall be covered with at least six inches (6") of earth. Manhole**

b) **covers which terminate above grade shall have either an effective locking device or otherwise be adequately sealed in a manner to prevent accidental access; and**

c) A six-inch (6") inspection port shall be provided over the inlet and outlet baffles of each tank and terminate at or above grade. An inspection port shall not be used as a pumpout access. A manhole cover at or above grade may also serve in place of an inspection port;

14. Compartmentation of single tanks shall be in accordance with the following:

a) Septic tanks larger than fifteen hundred gallons (1500 gals.) and fabricated as a single unit shall be divided into two (2) or more compartments;

b) When a septic tank is divided into two (2) compartments, not less than one-half (1/2), nor more than two-thirds (2/3), of the total volume shall be in the first compartment;

c) When a septic tank is divided into three (3) or more compartments, one-half (1/2) of the total volume shall be in the first compartment and the other half equally divided in the other compartments;

d) Connections between compartments shall be baffled so as to obtain effective retention of scum and sludge. The submergence of the inlet and outlet baffles of each compartment shall be as specified in paragraphs (4) (B) 7. and 8. of this rule;

e) Adequate venting shall be provided between compartments by baffles or by an opening of at least fifty (50) square inches near the top of the compartment wall; and

f) Adequate access to each compartment shall be provided by one (1) or more manholes with a minimum opening twenty inches (20") square or in diameter and located within six feet (6') of all walls of the tank;

15. The use of multiple tanks shall conform to the following:

a) Where more than one (1) tank is used to obtain the required liquid volume, the tanks shall be connected in series;

b) Each tank shall comply with all other provisions of this section;

c) No more **than three (3) tanks** in series can be used to obtain the required liquid volume; and

d) The first tank shall be no smaller than any subsequent tanks in series;

16. The liquid capacity of a septic tank serving a dwelling shall be based upon the number of bedrooms contemplated in the dwelling served and shall be at least as large as the capacities given in Table II

**Table III—Dwelling Septic Tank Capacity\***

Number of Bedrooms	Minimum Liquid Capacity (gallons)
1–3	1000
4	1250
5	1500

\* These figures provide for use of garbage grinders, automatic clothes washers and other household appliances. Garbage grinders are not recommended due to introduction of fats.

- a) For six (6) or more bedrooms, the septic tank shall be sized on the basis similar to an establishment. See paragraph (4) (B) 17. of this rule.
- b) No tank shall be installed that retains less than two (2) days' (forty-eight (48) hours') flow; and

17. For individual residences with more than five (5) bedrooms, multiple-family residences, and individual septic tank systems serving two (2) or more residences or any place of business or public assembly where the design sewage flow is greater than one thousand gallons per day (1000 gpd), the liquid capacity of the septic tank shall be designed in accordance with the following:

$V = 1.5Q + 500$  where V = the liquid capacity of the septic tank and Q = the design daily sewage flow.

**The minimum liquid capacity of a septic tank serving two (2) or more residences shall be fifteen hundred gallons (1500 gals.).**

**(C) Location.** Location of the sewage tank shall include the following:

- 1. The sewage tank shall be placed so that it is accessible for the removal of liquids and accumulated solids;
- 2. The sewage tank shall be placed on firm and settled soil capable of bearing the weight of the tank and its contents; and
- 3. **All tanks shall be bedded in a minimum of four inches (4") depth gravel measuring no more than three-quarter inch (¾") in diameter; and**
- 4. The sewage tanks shall be set back as specified in Table I of this rule.

**(D) Solids Removal.** The owner of any septic tank or his/her agent shall regularly inspect and arrange for the removal and sanitary disposal of septage from the tank whenever the top of the sludge layer is less than twelve inches (12") below the bottom of the outlet baffle or whenever the bottom of the scum layer is less than three inches (3") above of the bottom of the outlet baffle.

Yearly inspections of septic tanks are recommended and tanks shall be pumped whenever the bottom of the scum layer is within three inches (3") of the bottom of the outlet device or the sludge level is within eight inches (8") of the bottom of the outlet device. **When a repair is made to any part of an on-site wastewater treatment system, the tank shall be pumped and baffles inspected. Tanks of sound construction may be retrofitted with a manhole riser installed in accordance with paragraph (4) (13) (b) of this section.**

**(E) Septic Tank Filters.** Septic tank filters, if designed, installed and maintained properly, may prevent solids from entering the absorption field, thus extending the life expectancy of the field. Tank filters do not, however, eliminate the need for routine pumping of the septic tank and the routine cleaning of the filter. The frequency of pumping and cleaning depends on the habits of the user. Septic tank filters are recommended, and when used, shall follow these criteria:

- 1. The septic tank filter must be of durable construction and not subject to corrosion or decay.
- 2. The filter must have a filtration capability of 1/16" for alternative systems utilizing small holes in the absorption field or 1/8" for standard and modified standard systems.
- 3. The filter must be made accessible to the ground surface by installing a manhole access.
- 4. The filter shall be installed in accordance with the manufacturer's recommendations.

**(F) Pump Tanks.**

- 1. All pump tanks must be preceded with a septic tank filter installed in accordance with paragraph (4) (E).
- 2. Tanks for pumping effluent to a higher elevation (not for dosing) shall be a minimum volume equivalent to the greater of 500 gallons or one day's flow. Example:

$3BDR = 360 \text{ gpd} = 1000 \text{ gallon septic tank plus a } 500 \text{ gallon pump tank (to move the effluent).}$

- 3. All pump tanks must meet the construction and installation requirements of septic tanks. A good

quality, submersible effluent pump with oil lubricated bearings must be used. A grinder pump is not required because the septic tank effluent will be relatively free of solid material. A septic tank effluent pump or a submersible sump pump that will not be corroded by sewage should be used in the pumping chamber. Pumps with built in switches should be avoided, unless the switch can be adjusted for the quantity of water to be pumped.

4. Pumps in the range of 1/4 horsepower to 4/10 horsepower generally provide sufficient capacity for residential systems, but the pumping requirements for each system must be checked against the performance curve of the pump to be used.
5. The controls for the pumping system include a switching control for turning the pump on and off and a high- water alarm to signal pump malfunctions. The pump control system should be mercury switches and adjustable to meet the recommended loading rate for different sizes and shapes of the pumping chamber. The controls must also be sealed against entry of corrosive and explosive gases from the effluent and shall have NEMA (National Electrical Manufacturing Association) approval. All electrical connections (including low voltage) must be made outside of the pump chamber unless a NEMA approved "explosion proof box" is used and documentation is provided. Switches are activated by a sealed float. Best performance has been obtained using two switches - one to close the pump circuit and the other to open it.
6. In addition to the on and off control floats, a separate control switch is needed for the high-water alarm. This switch should be mounted several inches above the "on" float. The high-water alarm consists of a visible and audible signal mounted over a sign marked "wastewater system alarm" in a visible place. It must be on a separate electrical circuit from the pump power line, and be equipped with a test switch. The alarm is activated if the water level in the pumping tank rises above the "pump on" float control. The tank provides at least one day or more of excess storage capacity (depending on water use in the home), during which time the system must be repaired.
7. Complete control boxes for high-water alarms are available commercially. Simpler and less expensive systems can be assembled by an electrician. There are two basic requirements for an alarm system:
8. Filtered pump vaults are an option that is designed to be inserted into the septic tank thus eliminating the separate pump tank. These vaults are allowed for use only when connecting to a wastewater treatment plant and must be installed by a licensed

installer in accordance with construction standards found in (F) (2).

- a) There is less space for movement of conventional float switches in the pump vault so the manufacturer's recommendations for float switches must be followed by the designer. Those recommendations must be included with the submitted sketch design.
9. **Siphon Dosing/Siphon tanks shall be the same specification as other pump tanks, water tight, five hundred (500) gallon capacity or 100% of daily use, whichever is greater. The siphon shall be preceded by a filter. Two chambered tanks or separate tanks are preferred over screened siphon vaults in the septic tank. The system delivers effluent to standard or shallow placement trenches. The siphon should discharge at the rate of six hundred (600) gallons per hour but no more than two thousand seven hundred (2700) gallons per hour. A battery operated digital counter with the activating float switch located near high water level is a good indication of normal operation. This is a safeguard against the siphon operating in trickle mode unnoticed. The siphon should be inspected on a six month interval by the owner or owner-agent. Siphons shall not be used in LPP applications.**

**For pump tanks for a residence that has an outbuilding such as a garage or work shop with a toilet and hand sink and no kitchen, the following may be applied:**

1. **Gravity feed from structure to residential septic tank using 4" schedule 40 as outlined in Section 3 of this standard.**
2. **If the outbuilding is at a lower elevation and requires a pump to move effluent to the residential OWTS system then the following will apply:**
  - a) **A signed agreement attached to the OWTS permit stating that the outbuilding use is minimal and not for commercial use.**
  - b) **A small two (2) compartment pump tank with controls and alarms as described in Section 2 (F) shall be installed. The size of the tank will be based on 25 gallons per day times the occupancy capacity of the residence (based on 2 people per bedroom) as indicated on the original OWTS permit.**

**The two compartment tank with a filter shall be utilized if a conventional pump is installed. A single compartment tank may be used in conjunction with a grinder pump.**

The effluent will be pumped to the inlet side of the residential septic tank.

A riser extending above ground will be installed over the pump side of the tank for maintenance access.

With the use of these small tanks, a check valve may need to be installed to keep the pump from constant cycling due to the effluent in the pump draining back into the pump tank.

**(G) Aeration Units.**

An aeration wastewater treatment unit utilizes the principle of oxidation in the decomposition of sewage by the introduction of air into the sewage. An aeration unit may be used as the primary treatment unit instead of a septic tank except where special local conditions may limit their use. All aeration unit type treatment systems shall comply with the general requirements for sewage tanks set forth in these standards and with the following:

**1. Limitations.**

Special conditions where aeration units should not be used may include, but not be limited to, the following:

- a) Where intermittent use will adversely affect the functioning of the unit;
- b) Where dependable maintenance service is not available;
- c) Where electrical service is unreliable; and
- d) Where local ordinances restrict their use.

**2. General.**

The aeration unit shall be located where it is readily accessible for inspection and maintenance. Set-back distances for aeration units shall be in accordance with Table I of these standards.

**3. Design.**

- a) All aeration units shall receive approval with at least one of the following and with Christian County Health Department approval:
  - i) National Sanitation Foundation Standard No. 40
  - ii) Missouri Department of Health Environmental Engineer
- b) The aeration unit shall have a minimum treatment capacity of one hundred twenty (120) gallons per bedroom per day or five hundred (500) gallons, whichever is greater.

- 4. Effluent disposal. Effluent from an aeration unit shall be discharged into a soil absorption system or other final treatment system in accordance with Section 6 of these standards. **No reductions in the area of soil absorption systems or other final treatment systems shall be permitted because of the use of an aeration unit. Direct surface**

**discharge from an aeration unit treatment plant shall not be permitted.**

- 5. Operation and maintenance. Where aeration units are used, institutional or administrative arrangements to control their use, operation, and maintenance are recommended. Aeration units shall be pumped at least once a year to remove excess solids from the plant. An alarm shall be placed on a separate circuit.

**(H) Grease Traps**

Grease traps shall be required at food service facilities, meat markets, and other places of business where the accumulation of grease or oils can cause premature failure of a soil absorption system. The following design criteria shall be met.

- 1. The grease trap shall be located as close to the fixtures being served as possible and shall be plumbed to receive all wastes associated with food handling but no toilet wastes.
- 2. The grease trap liquid capacity shall be sufficient to provide for at least five gallons (5 gals.) of storage per meal served per day or at least two-thirds (2/3) of the required septic tank liquid capacity, whichever is greater. The following equation may be used to size the grease trap:

$$LC = D \times GL \times ST \times HR/2 \times LF$$

LC = liquid capacity of grease trap in gallons

D = number of seats in dining area

GL = gallons of wastewater per meal  
(1.5 single-service; 2.5 full service)

ST = storage capacity factor;  
minimum of 2.5

HR = number of hours open

LF = loading factor,

1.25 interstate highways

1.0 other highways and recreational areas

.8 secondary roads

- 3. Two (2) or more chambers must be provided, with total length-to-width ratio at least two to one (2:1). Chamber opening and outlet sanitary tee must extend down at least fifty percent (50%) of the liquid depth.
- 4. Access manholes, with a minimum diameter of twenty-four inches (24"), shall be provided over each chamber and sanitary tee. The access manholes shall extend at least to finished grade and be designed and maintained to prevent surface water infiltration. The manholes shall also have readily removable covers to facilitate inspection and grease removal.



## (5) ABSORPTION SYSTEMS.

The common design of absorption systems is the use of absorption trenches, each separate from the other and each containing a distribution pipe. This type system should be used whenever practical. Other types of absorption systems may be used as alternatives where the site conditions meet the specific design requirements of the alternative systems. Installation shall not be made while the soil is wet or moist. This is to prevent smearing and destroying the structure of the soil.

1. **Absorption Trenches.** The absorption trench gives additional treatment to the sewage from the treatment tank. Regardless of its appearance of clarity or transparency, the outflow or effluent from a sewage tank is a dangerous source of contamination. The satisfactory operation of the sewage disposal system is largely dependent upon the proper site selection, design and construction of the absorption trench.
2. Standard absorption trench systems shall not be constructed in soils with loading rates lower than 0.2 gpd/sq.ft.
3. The absorption trench shall be designed to maximize the vertical separation distance from the bottom of the absorption trench to the seasonal high water table or limiting layer. The vertical separation between the bottom of the absorption trench and limiting layer or seasonal high water table **shall be no less than one (1) foot –for conventional standard systems.** There shall be a minimum of six inches (6") of vertical separation between the bottom of the absorption trench and any clayey horizon (greater than 35% clay), **if the clayey horizon is eighteen (18) inches or deeper. If the clayey horizon is less than twenty four inches (24") deep then shallow placement shall be utilized if other soil properties permit.**
4. **Depth to bedrock:** Sites that do not meet the minimum soil requirements for any specified system shall utilize a Department approved advanced treatment component (ATC) for a subsurface wastewater system, if other site factors permit.
5. **Low to moderate permeable bedrock: Standard (conventional and modified) absorption trenches without an ATC shall have a minimum of two feet (2') separation distance between the bottom of the absorption trench and bedrock or paralithic contact at the shallowest known point within the represented area.**
6. **Highly permeable bedrock: Standard, combined wastewater absorption trenches without an ATC shall have a minimum of three feet (3') separation distance between the bottom of the absorption trench and bedrock or paralithic contact at the shallowest known point within the**

represented area. The following systems may be used with a minimum of two feet (2') separation distance within the represented area if other site factors permit:

- a) **A low pressure pipe (LPP) system with a maximum loading rate of two tenths (.2) gallons per day per square foot and a curtain drain. If technically possible, a split manifold design shall be used for LPP systems for improved distribution;**
  - b) **A black/gray water system with shallow placement trenches or alternative absorption system, and a curtain drain for the black water portion. If technically possible the black and gray water systems shall be offset, one not directly up-slope of the other;**
  - c) **An ATC with shallow placement trenches or alternative absorption system;**
  - d) **Another Department approved system.**
7. Absorption trenches shall not be constructed in ground which has become severely compacted.
  8. Absorption trenches shall not be constructed in soils which are wet. Soils that are not wet but moist enough to smear trench walls shall not be worked unless trench surfaces are manually (amended) scratched.
  9. Absorption trenches shall not be constructed in excavated soils, unless the soil scientist documents that the excavation will not interfere with treatment of the effluent. **For disturbed soil to be utilized, the site evaluator shall state the soil has stabilized and has less than 27% clay content, and shall address the following factors: the presence and quantity or absence of high chroma mottles; presence or absence of any areas of relatively high bulk density soil; all types and quantity of soil structure present; presence and quantity or absence of large pores; any non-prevalent unsuitable soil factors and list the percentage of the total soil the unsuitable soil factor comprises. Approval of disturbed soil will be subject to Departmental approval.**
  10. Absorption trenches shall not be backfilled with soils that are frozen or saturated.
  11. Soils with a moderate limitation rating due to excessive rock fragment content shall utilize a parallel distribution system if it is technically possible to utilize a Department approved gravity flow dipper distribution box. **One hundred feet (100') long absorption trenches shall be utilized, if site conditions permit, to extend the field over as wide (across the slope) of an area of the landscape as possible. Shallow placement shall be utilized, if other soil factors permit.**
  12. Soils with a severe limitation rating due to a rock fragment content greater than fifty percent (50%),

- but no greater than seventy percent (70%), shall meet the requirements listed above for soils with a moderate limitation rating due to excessive rock content. In addition, if the soil permeability is rapid enough for sand-lined trenches, a sand-lined gravelless pipe system, or a low pressure pipe (LPP) system with sand-lined trenches, or another CCHD approved system will be required. **A serial (step-down/drop-box) distribution system is never permitted with a soil type that is suitable for sand-lined trenches. Shallow placement is not required with a sand-lined system.**
13. Soils with a severe limitation rating due to rock fragment content of greater than seventy percent (70%) shall meet the requirements listed above for soils with **fifty to seventy percent (50-70%)** rock fragment content. **In addition, due to the minimum amount of soil, the small percentage of soil types in this category that have a permeability too slow for sand-lined trenches must have another system approved by CCHD that shall be of higher quality than the standard, combined black and gray effluent, shallow placement system. A serial (step-down/drop box) distribution system shall not be permitted under any circumstance for this category of soils. Systems that may be permitted for this category, when sand-lined trenches are not appropriate, include the black/gray water system, LPP system, or an advanced treatment component system.**
  14. The minimum size standard or modified standard absorption system shall be six hundred (600) square feet.
  15. Each absorption trench system shall have a minimum of two (2) trenches with no one (1) trench longer than one hundred feet (100'). The absorption trenches shall be located not less than three (3) times the trench width on centers with a minimum spacing of six feet (6') on centers. The site evaluator may offer these design recommendations: The minimum length of the lowest trench should be equal to or greater than the other trenches and should be a minimum of fifty feet (50'). The number of stepdowns or drop boxes should be kept to a minimum. The minimum trench spacing should be increased to fifteen feet (15') for sites requiring modified trenches due to a limiting layer or a seasonal high water table. These design recommendations must be addressed on the soil evaluation form.
  16. Absorption trenches shall be at least eighteen inches (18") wide and no greater than thirty-six inches (36") wide. The bottom of conventional standard absorption trenches shall be eighteen inches (18") below natural grade unless justified otherwise by the site evaluator, due to the topography or unusual soil conditions and specifically approved by CCHD on a case by case basis. In no case shall the trench be greater than thirty inches (30") below finished grade.
  17. Gravity-fed absorption field distribution lines shall be at least four inches (4") in diameter. Perforated distribution lines shall be used. The perforations shall be at least one-half inch (1/2") and no more than three-fourths inch (3/4") in diameter.
    - a) All perforated pipe used in the absorption system shall be a minimum of ASTM Standard D-2729. ASTM Standard D-2729 is a minimum of 2500 lb. crushproof. Perforated pipe with (3) rows of holes shall not be used. The perforated pipe used in the absorption field shall be laid with the lettering/numbers up so they are visible for inspection and to insure the proper placement of holes.
    - b) When four (4) - or six (6) -inch diameter corrugated, rigid plastic tubing is used for distribution lines; it shall be certified as complying with ASTM standards F405. The corrugated tubing shall have two (2) or three (3) rows of holes, each hole between one-half inch (1/2") and three-fourths inch (3/4") in diameter and spaced longitudinally approximately four inches (4") on centers. The pipe shall be laid so the rows of holes are positioned at 4:00 o'clock and 8:00 o'clock. Three-hole corrugated pipe shall be placed in a manner that no holes are between 4:00 o'clock and 8:00 o'clock. **COILED TUBING SHALL NOT BE USED.**
  18. For inspection, all trenches shall be left uncovered to the barrier material. In addition to this, the absorption trench shall be left completely open to a minimum length of eighteen inches (18") at the trench bottom, at a minimum of two (2) approximately equally spaced locations per 100 feet (100') of trench. For all non-level systems, the absorption trench lines shall be marked on the contour for excavation utilizing a calibrated level. The absorption trenches shall be constructed as level as possible but in no instance shall the fall in a single trench bottom exceed one-fourth inch (1/4") in ten feet (10') as determined by an engineer's level. The ends of distribution lines shall be capped or plugged, or when they are at equal elevations, they should be connected. All caps shall be exposed for inspection. Step downs within the absorption trenches are not allowed.
  19. Rock used in soil absorption systems shall be clean, washed gravel or crushed stone and graded or sized between one to two and one-half inches (1" to 2 1/2") with no more than ten percent (10%) material to pass through a one-half inch (1/2") screen. Limestone, dolomite or other crushed rock shall be

avoided when possible. If limestone, dolomite or other crushed rock is used, it shall be washed and be a minimum size of one and one-half inches (1 1/2") to a maximum size of three inches (3"). The rock shall be placed a minimum of one foot (1') deep with at least six inches (6") below the pipe and two inches (2") over the pipe and distributed uniformly across the trench bottom and over the pipe. The backfill soil shall not be wet **or frozen** and shall have a silt loam or coarser texture. The upper twelve inches (12") of the undisturbed soil is usually suitable for backfilling unless the site evaluator designates otherwise. Before placing soil backfill over the trenches, the gravel shall be covered with one of the following:

- a) Unbacked, rolled, three and one-half inch (3 1/2") thick fiberglass insulation;
- b) Untreated building paper;
- c) Synthetic drainage fabric;
- d) A minimum of eight inches (8") of straw for a compacted thickness of two inches (2"); or
- e) Other material approved by the Christian County Health Department lay as to separate the gravel from the backfill.

20. Complex slope patterns and slopes dissected by gullies shall not be considered for installation of absorption trenches. When slopes are less than two percent (2%), provisions shall be made to insure adequate surface drainage. For all non-level systems, the absorption trenches shall follow the contour of the ground. If technically possible, slopes greater than **twenty percent (20%)** and foot-slope landscape positions shall require installation of interceptor drains, except for soils that require the use of sand-lined trenches, upslope from the soil absorption system to remove all excess water that might be moving laterally through the soil during wet periods. Usable areas larger than minimum are ordinarily required in this slope range. Slopes greater than thirty percent (30%) shall not be utilized for absorption trenches unless no other alternative exists and provisions can be made to deal with the limitations.
21. Bottom positions, including drainage ways, shall not be used for absorption trenches. Replacement sites that cannot avoid bottomland positions shall utilize, if the site permits, the following minimum criteria: an eighteen inch (18") trench depth, a level distribution system and a maximum trench width of twenty-four inches (24") if a level system can be used.
22. Effluent distribution devices, including drop boxes, distribution boxes, dipper boxes, flow dividers, and engineered flow diversion devices, shall be of sound construction, watertight, not subject to excessive corrosion and of adequate design as approved by the Christian County Health

Department. Effluent distribution devices shall be separated from the sewage tank and absorption trenches by a minimum of two feet (2') of undisturbed or compacted soil and shall be placed level on a solid foundation of soil or concrete to prevent differential settlement of the device. The pipe entering and exiting any distribution device shall be laid with the letters/numbers up so they are visible for inspection.

- a) Each distribution line shall connect individually to the distribution device. A minimum of five-feet (5') of SCH 40 pipe shall exit the distribution device.
  - b) The pipe connecting the distribution device to the distribution line shall be of a tight joint construction laid on undisturbed earth or properly bedded throughout its length. The pipe will be laid with the letters/numbers up so they are accessible for inspection.
  - c) **The boxes shall be left uncovered until after the trenches are backfilled. Equal distribution devices shall be made accessible for periodic inspection by installing a manhole access.** The installer shall check with water during installation and after backfilling of trenches to ensure they are functioning properly.
23. **Distribution boxes for equal (parallel) distribution-Only dipper type or engineered flow diversion boxes may be used. Engineered flow diversion boxes shall be limited to sites that do not have the necessary slope to utilize the dipper distribution box. A filter and maintenance contract should be in place for dipper type and engineered flow diversion boxes with up to four (4) distribution lines. Dipper type or engineered flow diversion boxes with greater than four (4) but not more than six (6) distribution lines shall have a filter installed and maintenance contract in place.**
  24. Stepdowns or drop boxes **may** be used where topography prohibits the placement of absorption trenches on level grade.
  25. **Drop boxes** shall be constructed so that the inlet supply pipe is one inch (1") above the invert of the outlet supply pipe which is connected to the next lower drop box. The piping connecting drop boxes shall be schedule 40 PVC or better. The top of the trench outlet laterals, which allow effluent to move to the distribution lines, shall be two inches (2") below the invert of the outlet supply line. The pipe connecting drop boxes to absorption lines shall be schedule 40 PVC and a minimum of five feet (5') in length. Drop boxes shall be designed to close off the trench outlets to provide for periods of resting if the absorption trench becomes saturated.

26. **Stepdown** relief trenches shall be constructed of a minimum of two feet (2') of undisturbed soil and constructed to a height level with the top of the upper distribution line. It is preferred that the entire trench relief line be constructed in undisturbed soil. Under no circumstances shall gravel be placed in the trench relief line. The inlet to a trench line should be placed either in the center or as far as practical from the outlet (overflow) from the same trench. All piping and joints used in the stepdowns shall be schedule 40 PVC or better. All piping in the stepdown shall be laid with the letters up. Stepdown must consist of a twenty-two and one-half degrees (22.5°) joint placed so that the upper distribution line will fill two inches (2") before effluent fills the twenty-two and one-half degrees (22.5°) joint.
27. A pump distribution system may be installed where a more even distribution of effluent is desired. A pump is utilized to send effluent to a manifold where the flow to the distribution trenches is controlled by a valve at the beginning of each trench. A manometer is installed between the flow control valve and the header pipe. In this configuration all lines will be set with the same back pressure (2 to 4 feet of head pressure). After the pressure is set and inspected the manometers are removed and the tee fitting capped. Valves will be covered with landscaping type boxes for future access. The solid pipe is usually one inch (1") to two inches (2") depending on flow rates. All solid pipe is schedule 40.
28. Standard and modified standard absorption trenches may be utilized with this delivery system.
29. **Other equal distribution systems may be used with CCHD approval and will rely on MDHSS approval. These systems will be required to be designed by a registered engineer.**
30. Dosing is required for systems to provide improved distribution to absorption trenches:
- When the design sewage flow per septic tank outlet requires more than five hundred (500) lineal feet of distribution line.
  - When the design sewage flow requires more than one thousand (1,000) lineal feet of distribution line, the absorption field shall be divided into two (2) equal portions and each half dosed alternately, not more than four (4) times per day.
  - Dosing shall be accomplished by the use of an engineered siphon or a pump. Each side of the system shall be dosed not more than four (4) times per day. See section for siphon tanks.
31. **Gravelless Pipe** Gravelless subsurface absorption systems may be used as an alternative to conventional four-inch (4") pipe placed in gravel filled trenches. However they cannot be used for shallow placement systems as defined in this code. The trench for the gravelless system shall be dug with a level bottom.
- The eight (8) and ten (10)-inch (inner diameter) corrugated polyethylene tubing used in gravelless systems shall meet the requirements of ASTM F667, Standard Specification for Large Diameter Corrugated Polyethylene Tubing. The eight inch (8") may be considered equal to an eighteen inch (18") wide standard absorption trench. The ten inch (10") pipe may be considered equal to a two foot (24") wide absorption trench.
  - Two (2) rows of perforations shall be provided and located one hundred twenty degrees (120°) apart along the bottom half of the tubing, each sixty degrees (60°) from the bottom centerline. Perforations shall be cleanly cut and uniformly spaced along the length of the tubing and shall be staggered so that there is only one (1) hole in each corrugation. The tubing shall be visibly marked to indicate the top of the pipe. All gravelless drainfield pipes shall be encased at the point of manufacture with a spun bonded nylon filter wrap. On sloping ground, the trench shall follow the contour of the ground to maintain a level trench bottom and to ensure a minimum backfill of six inches (6"). It is required that the minimum trench width for the gravelless system be eighteen inches (18") in friable soils to ensure proper backfill around the bottom half of the pipe. In cohesive soils, the minimum width of excavation shall be twenty-four inches (24"). For non-sand-lined trenches, the gravelless system shall have the same trench depth requirements as for conventional standard trenches. To promote equal effluent and suspended solids distribution, the slope of the drain pipe should be from zero to one-half inch (0-.5") per one hundred feet (100').
  - Polystyrene Aggregate Absorption Field Systems**  
Non experimental Polystyrene Aggregate Absorption field systems which have received acceptable reviews by the Missouri Department of Health and Senior Services Environmental Engineer may be used. These systems will be installed according to the MDHSS Environmental Engineer's review and as outlined in section (5) (22) of this code, and with the manufacturer's specifications. If a conflict arises between the CCHD OWTS standards and the manufacturer's specifications, then the CCHD OWTS standards will take precedence.

32. **Chamber Systems** The CCHD may permit the use of chamber systems on sites where the soil-loading rate is  $\geq 0.3$  gpd/sq. ft. The other requirements of these standards relative to depth to restrictive horizons, maximum depth of trenches, etc. shall also be met. When using chamber systems the fifteen inch (15") chamber may be considered equal to twenty-four inches (24") in width of a standard absorption trench. The twenty-two inch (22") chamber may be considered equal to twenty-eight inches (28") in width of a standard absorption trench. The thirty-four inch (34") chamber may be considered equal to forty-two inch (42") in width of a standard absorption trench. Chambers must have a minimum of six inches (6") of cover after settling and cannot be used for shallow placement as defined in this code. **(NOTE: In order to achieve six inches (6") of settled soil there would need to initially be eight (8") to twelve (12") inches of cover at the center of the each of the trenches).**

a) Installation of the chamber system shall be in accordance with this rule except:

- i) The installation shall be made in accordance with the manufacturer's specifications;
- ii) The side walls of trenches placed in Group IVa soils shall be raked to open pores which were damaged or sealed during excavation; and
- iii) Chambers utilizing maximum sidewall absorption features shall be installed per the manufacturer's recommendations to maximize the use of upper soil horizons; and

33. Dosing/alternating systems are encouraged, especially in slowly permeable soil conditions.

34. The CCHD may permit the use of a bed system on sites where the minimum soil loading rate is 0.4 gpd/sq. ft. and essentially meeting the other requirements of this section, and only on lots which are limited by topography, space or other site planning considerations. In such cases the number of square feet of bottom area needed shall be increased by fifty percent (50%) over what would be required for a trench system. Distribution lines shall be at least eighteen inches (18") from the side of the bed and shall have lines on three-foot (3') centers. When the design volume of sewage exceeds six hundred (600) gallons per day, adequate space shall be provided to accommodate a trench system for the absorption field.

35. Possible modifications to standard absorption systems which may be utilized to overcome selected soil and site limitations, and must be approved by the CCHD, include the following:

**Shallow Placement** of absorption trenches is commonly utilized where there is less than thirty inches (30") from

the surface to a seasonal high water table or limiting layer, but generally can be used anywhere standard trenches are permitted. (A shallow placement system consists of trenches excavated twelve inches (12") deep into natural soil, filled with gravel to the original ground surface and then the entire absorption field covered with a minimum of six inches (6") and a maximum of twelve inches (12") of dry silt loam or coarser texture soil **after settling**. **(NOTE: In order to achieve six inches (6") of settled soil there would need to initially be eight (8") to twelve (12") inches of cover at the center of the each of the trenches).**

36. The cover over the absorption field shall extend at least five feet (5') beyond the edge of any absorption trench. Interceptor drains are required on all shallow placement systems where the seasonal high water table or limiting layer is less than thirty inches (30") from the original surface. Shallow placement can generally be utilized where conventional standard trenches are used; for soils with a severity rating of one (1) or two (2); for soils with a higher severity rating in conjunction with specified advanced systems.

37. Alternating dual field absorption systems may be utilized where soils are limited by high clogging potentials. Alternating dual field absorption systems shall be designed with two (2) complete absorption fields, each sized a minimum of seventy-five percent (75%) of the total area required for a single field and separated by an effluent flow diversion valve. The diversion valve shall be constructed to resist five hundred pounds (500 lbs.) crushing strength, structurally sound and shall be resistant to corrosion. Valves placed below ground level shall be installed so that it may be operated from the ground surface.

38. Sand-lined trenches may be used in areas where the soil has greater than fifty-percent (50%) rock fragments and meets the soil requirements for sand-lined trenches in this section and as specified in section (5) (A) 9 for soils with a severe limitation rating due to a high gravel content. The material must be natural or manufactured sand and have no more than fifteen percent (15%) clay content. Clean river sand that is screened to 1/4" and smaller may be used. Manufactured sand from chert "flint" shall not be used. The sand used for the liner shall contain less than twenty-five percent (25%) material retained on a No. 10 sieve. Finely crushed limestone is not acceptable.

- (a) Sand-lined trenches shall only be used with gravelless and polystyrene aggregate systems.
- (b) In gravelless pipe systems the minimum thickness of liner material is six inches (6") on the sides of the pipe and twelve inches (12") below the pipe. The effluent to sand-lined systems should be equally distributed as much

as practically possible. Dosing is recommended in order to more positively assure even distribution.

- (c) For sand-lined trenches to be permitted, the permeability of the natural soil material must be similar or higher than the permeability of the liner material. Sand-lined trenches must not be used over fragipans or other restrictive layers which have perched water tables and could cause saturation of the liner material.

- 39. Curtain drains shall be required where there is less than eighteen inches of separation between the trench bottom and the uppermost elevation of the seasonally high water table or limiting layer. Curtain drains shall be dug at least six inches (6") into the limiting layer and filled with gravel, as a minimum, to the same depth as the perched water table or six inches (6") above the top of a limiting layer, whichever is shallower, and cover the gravel with building paper or other suitable barrier material. Curtain drains must be daylighted on at least one end, preferably on both ends. Screens shall cover the daylighted end of the pipe. If the curtain drain cannot be daylighted on site then a sump-pump may be used at one end of the curtain drain, and the water pumped to the surface, away from the lateral field, or the system can meet the requirements for a soil with the next higher severity rating that has an additional provision. Coiled tubing is not approved for use in the curtain drains. Perforated pipe of the same strength as laterals shall be placed on one to two inches (1-2") of gravel in the bottom of the trench with the holes pointed down. Curtain drains may vary in width and be dug with either a backhoe or a trencher.
- 40. Diversion berms - Diversion berms may be used to keep surface water from contributing to high soil moisture levels in the absorption field areas. Diversion berms shall be located generally along the surface contour.

#### **(6) Wastewater Stabilization Ponds**

A wastewater stabilization pond can provide satisfactory sewage treatment in rural areas where soils are not suited for absorption systems. Single residence wastewater stabilization ponds are not generally suitable in subdivisions with lots less than three (3) acres in size.

**Ponds may be utilized when there are no significant limitations related to groundwater from their use and the natural soils have a limiting layer such as hardpan or 4b clay.** There shall be a minimum separation distance between the pond bottom and highly permeable bedrock of three feet (3') and two feet (2') for low/ moderately permeable bedrock. Ponds shall not be approved for sites overlying highly permeable bedrock unless the soil has a restrictive pan horizon with a

minimum thickness of twelve inches (12"). Compacted clayey soil may be added to meet the minimum separation distance.

Natural restrictive or other limiting soil layers required for pond construction shall be a minimum of twelve inches (12") thick and shall not be breached during construction. To help assure the limiting layer will not be breached the soil scientist shall conduct an on-site visit to the specific pond site. Ponds constructed in or on restrictive pan horizons shall have the pan surface lined with a minimum of one pound of bentonite clay per square foot (1lb/sq.ft.) and worked into the surface. Polyethylene or similar materials may be used with departmental approval.

- 1. Selection of the pond site should consider a clear sweep of the surrounding area by prevailing winds. Heavy timber should be removed for a distance of fifty feet (50') from the water's edge to enhance wind action and prevent shading.
- 2. Steeply sloping areas should be avoided.
- 3. The Christian County Health Department may require that a properly sized and constructed septic tank or aeration unit precede the pond. (Section (4) Sewage Tanks). The use of a septic tank or aeration unit shall not be used as a basis for reduction of the set-back distances as set forth in these standards.
- 4. The pond shall be designed on the basis of four hundred forty (440) square feet of water surface area per bedroom at the three-foot (3') operating level. Whenever the pond is preceded by a septic tank or aeration unit, the water surface area may be reduced up to a maximum of twenty percent (20%); however, the minimum water surface area at the three foot (3') level shall be nine hundred (900) square feet.
- 5. A single cell is generally acceptable for single residence pond systems. If multiple cells are used for further polishing or storage of the effluent, the secondary cell should be one-half (1/2) the size of the primary cell.
- 6. The minimum embankment top width shall be four feet (4'). The embankment slopes shall not be steeper than three to one (3:1) on the inner and outer slopes. Outer embankment slopes shall be sufficient to prevent the entrance of surface water into the pond. Freeboard shall be at least eighteen inches (18") and preferably twenty-four inches (24"). Additional freeboard may be provided.
- 7. Embankments shall be seeded with a locally hardy grass and **should be mulched** from the outside toe to one foot (1') above the water line to minimize erosion and facilitate weed control. Alfalfa or similar long rooted crops which might interfere with the water-holding capacity of the embankment shall not be used. Riprap may be necessary under unusual conditions to provide protection of

- embankments from erosion.
8. The influent line shall be of a sound, durable material of water-tight construction. The line shall have a minimum diameter of four inches (4") (unless pumped) and be laid on a firm foundation at a minimum grade of one-fourth inch (1/4") per foot. The influent line shall discharge as far as practical from the possible outlet side of the pond. A cleanout or manhole (unless pumped) should be provided in the influent line near the pond embankment. From this point the line should be laid to the inner toe of the embankment and then on the bottom of the pond to the terminus point. A concrete splash pad three feet (3') square should be placed under the terminus of the pipe. The elevation of the cleanout or manhole bottom should be a minimum of six inches (6") above the high water level in the pond.
  9. The shape of the pond should be such that there are no narrow or elongated portions. Round, square, or rectangular cells are considered most desirable. Rectangular cells shall have a length not exceeding three (3) times the width. No islands, peninsulas, or coves shall be permitted. Embankments should be rounded at corners to minimize accumulation of floating materials.
  10. The floor of the pond shall be stripped of vegetation and leveled to the proper elevation. Organic material removed from the pond area shall not be used in embankment construction. The wetted area of the pond must be sealed to prevent excessive exfiltration. Seals consisting of soils must be adequately compacted by the construction equipment or a sheeps-foot type roller may be used.
  11. Embankments shall be constructed of impervious materials and compacted sufficiently to form a stable structure with very little settlement.
  12. Any effluent should be withdrawn from six inches (6") below the water surface. This can be accomplished by placing the outlet pipe eight to ten inches (8-10") lower on the inlet end than the outlet end of the pipe. The line shall be of a sound, durable material of water-tight construction. The line shall have a minimum diameter of four inches (4").
  13. The pond area shall be enclosed with a five-foot (5') high woven or chain-link fence to preclude livestock and discourage trespassing. This fence material shall be onsite at time of final inspection. The fence shall be so located to permit mowing of the embankment top and slopes. A gate of sufficient width to accommodate mowing equipment shall be provided. Appropriate warning signs shall be provided to designate the nature of the facility. The construction of this fence is the responsibility of the owner.
  14. Effluent from a pond must be disposed of on the

property from which it originated. This may be accomplished by locating the outlet as far as practical from the property line and out of any natural drainage ditches or swales. The minimum distance from the outlet to a property line shall be one hundred feet (100'). Another method is to construct a terraced swale with a minimum length of one hundred fifty feet (150').

15. It may be necessary to introduce water into the pond to facilitate start-up of the biological processes; however, there shall be no permanent connection of any roof drain, footing drain or any source of rainwater to the wastewater stabilization pond.

#### (7) **HOLDING TANKS**

The use of holding tanks is generally discouraged. **Use of a holding tank must be specifically approved by the CCHD and will not be approved for a permanent residence except in the case of replacement sites where not other method of treatment is feasible.**

1. A holding tank shall be constructed of the materials and by the same procedures as those specified for watertight septic tanks.
2. The holding tank must be provided with an above ground concrete or masonry (or their equivalent) manhole riser to provide easy access for pumping. The manhole riser must be wide enough to accommodate the existing lids on the tanks, extend at least six inches (6") above the finished grade of the site and be covered with a service lid. All joints must be sealed to prevent the infiltration of surface or ground water to the tank.
3. The tank shall be protected against flotation under high water table conditions. This shall be achieved by weight of the tank, earth anchors, or shallow bury depths.
4. For a residence, the size shall be one thousand gallons (1000 gals.) or four hundred gallons (400 gals.) times the number of bedrooms, whichever is greater. For permanent structures other than residences, the capacity shall be based on measured flow rates or estimated flow rates. The tank capacity shall be at least five (5) times the daily flow rate or one thousand (1000) gallons, whichever is greater.
5. Holding tanks shall be located as follows:
  - a) In an area readily accessible to the pump truck under all weather conditions;
  - b) Where accidental spillage during pumping will not create a nuisance.
  - c) **All pumping records shall be made available to CCHD upon request**
6. A contract for disposal and treatment of the sewage wastes shall be maintained by the owner with a pumper, municipality, agency or firm established

for that purpose. The owner shall keep records of who pumped the tank, when the tank was pumped, and where it was disposed. This contract will accompany the application for permit.

7. Holding tanks shall be monitored to minimize the chance of accidental sewage overflows. A high water alarm device shall be installed on all holding tanks so that it activates no higher than one foot (1') below the inlet pipe. This device shall be an audible and illuminated alarm.
8. Holding tanks used in conjunction with permanent black/gray water systems must conform to the requirements of this section except that the minimum size tank is one thousand gallons (1000 gals.).
9. In addition to the OWTS permit & Sketch plan submission to CCHD, the owner of the property must also complete a Holding Tank Acknowledgement form (San-14) describing the conditions of use for the holding tank. Holding tanks approved for use in an area located inside the standard setbacks for septic tanks shall be inspected by CCHD annually to test for water tightness. An inspection fee will be incurred by the property owner at each annual inspection. The inspection fee will be equal to a current trip charge amount for each visit to the site required to perform the test. Normally, this will consist of two trips: One to initiate the test and a second to check for any possible leakage. The holding tank should not be used during the 24 - 36 hour period in which the test is being performed.

It will be necessary to pump the holding tank after testing prior to further use.

CCHD reserves the right to require other specially designed safety features to be added to the system or property features in order to insure safety and welfare of the general public.

## **(8) ALTERNATIVE SYSTEMS.**

### **(1) General.**

The intent of this section is to provide basic information for the design, location, installation, use and maintenance of alternative sewage treatment systems in areas of limiting soil characteristics or where a standard system cannot be installed or is not the most suitable treatment.

### **(2) Low Pressure Pipe.**

The low pressure pipe system (LPP) is an alternative system that can be constructed in many areas where standard absorption trenches cannot. The LPP overcomes many problems with the site by utilizing uniform distribution of effluent, dosing and resting

cycles and shallow placement of the trenches. Soils rated severe due to seasonal high water tables, or limiting layer cannot have a severity rating higher than three (3) to be considered for a LPP system without a pretreatment component. The Christian County Health Department requires that all LPP systems be designed and constructed by an installer licensed specifically for LPPs. All construction requirements are found in Christian County's LPP manual.

### **(3) Wetlands.**

The constructed wetlands are an alternative system that provides secondary levels of treatment. This type of system requires some form of pretreatment such as septic tank, aeration tank, or lagoon. The CCHD requires that all wetlands be designed and constructed by an installer licensed specifically for alternative systems. All construction requirements for wetlands will be furnished to the installer at the time of licensing.

### **(4) Elevated Sand Mounds.**

The elevated sand mound is an alternative system that utilizes above ground soil absorption at the secondary level of treatment. The CCHD requires that all elevated sand mounds be designed & constructed by an installer licensed specifically for Alternative Systems. All construction requirements for elevated sand mounds will be furnished to the installer at the time of licensing.

### **(5) Sand Filter & Pea Gravel Filter and Bio-Peat Filter.**

The sand filter, whether buried or recirculating, is an alternative system that provides secondary levels of treatment. Open sand filters are not permitted in Christian County. The CCHD requires that all sand filters be designed and constructed by an installer licensed specifically for Alternative Systems. All construction requirements for sand filters will be furnished to the installer at the time of licensing.

### **(6) Other Systems.**

Where unusual conditions exist, special engineered systems of advanced treatment and disposal, other than those specifically mentioned in these standards, may be considered provided:

1. Reasonable assurance of performance of the system is presented to the Christian County Health Department;  
Specific technical data, not personal opinions or sales literature, is to be submitted to this department. An opinion from an engineer, soil scientist, or geologist regarding the system without specific technical data will not be considered for approval.



2. The Engineering design of the system is first approved by the Christian County Health Department. The report will specifically detail how no other system mentioned in these standards can successfully be employed on this site.
3. There is no discharge to ground or surface waters or if a discharge occurs a NPDES Operating Permit is first obtained by the applicant, and a copy provided to the CCHD.
4. Adequate substantiating data to indicate that the effluent will not contaminate any drinking water supply, groundwater used for drinking water, or any surface water;
5. Treatment and disposal of the wastes protects public health and general welfare; and
6. These systems comply with all applicable requirements of these standards and with all local codes and ordinances and all applicable requirements of chapter 701 of the Missouri statutes.
7. Specific construction criteria for these systems are not provided in these standards, therefore there will be a statement on the construction permit that this is an experimental system.

**OR**

1. Received an acceptable installation review by Missouri Department of Health Environmental Engineers and
2. Adequate, cost effective local training has been obtained by CCHD EPHS staff. Training will include, but not be limited to, installation, construction, and inspection guidelines for these systems and

Note: The normal five (5) day permitting process does not apply to Section (F) Other Systems. Permitting times will vary depending upon fulfillment of the above stated requirements.

**(I) Damage Renovation, (Replacement and Repair) to Properly Functioning Permitted Systems.**

Permitted systems that have received a final inspection approval may have the damaged sections listed below renovated (repaired or replaced) with materials that are in accordance with current standards. If the system had received a final inspection but approval was withheld, the entire damaged system must be renovated in accordance with current standards. These criteria shall be followed for damage repair, replacement or renovation of a permitted and **approved** system:

1. Broken, crushed or cut solid pipe, other than solid pipe in the absorption field, may be replaced.
2. Concrete sewage tanks, pump tanks, drop boxes or distribution boxes may be replaced. Any repair work to damaged concrete materials

will be considered on an individual case basis.

3. There will be no repair work done to damaged absorption field areas. The damaged section may be replaced with an amount of trench area that is equal to the amount of damaged area. If the site in which the damaged area is to be replaced is not within the represented soil area on the site evaluation or if the represented soil area is not specifically shown on the site evaluation, a report from a site evaluator will be required.
4. Damaged systems installed prior to the effective date of this ordinance, May 1, 1992, or constructed illegally after date without permit approval must be renovated in accordance with current standards.

**Renovation to Systems Installed Prior to May 1, 1992**

Sections 2.1 and 2.3 of the Christian County Wastewater Ordinance clearly state that all renovations to systems must meet the current standards. These criteria shall be followed for renovation of these existing systems:

1. There will be no repair to the existing soil treatment area. All existing soil treatment areas shall be replaced.
2. Septic tanks, of any construction, installed prior to May 1, 1992, may not be replaced without bringing all parts of the system into compliance with current standards. If the applicant believes that their existing system does meet current standards, the following criteria shall be followed in demonstrating that fact:
  - a) Before the applicant undertakes the effort and expense to prove a system existing prior to the ordinance does meet current standards these factors must be considered:
    - 1) The cost of hiring a site evaluator and a licensed installer to evaluate the existing system will most likely be in addition to the cost of evaluating for a replacement of the system.
    - 2) The site evaluation for the existing system may not necessarily be used for designing a replacement system. Each site evaluation must be in the area of the existing system and the replacement area respectively. If both sites are evaluated on the same form, the site evaluator must submit a statement regarding that.
    - 3) Replacing a rusted metal tank, that may have been leaking, with a watertight concrete tank may overload the absorption field and cause failure.

- b) Submit a site evaluation for the specific area of the existing system. In addition to the usual requirements of a site evaluation, as defined in these standards, the site evaluator must include a statement that this system is in compliance with current standards.
- c) Submit a statement from a licensed installer that this system is in compliance with current standards. This statement must include a sketch drawing of all system details that are required on proposed systems (trench layout, trench details such as depth, width, size of trench rock, depth of trench rock above and below the pipe, strength and type of pipe material, barrier material, etc.)
- d) The existing system shall be opened for department inspection including, at the minimum: the building sewer line from the building to the tank must be exposed near the foundation and near the tank. The solid line exiting the tank leading to the absorption field must be exposed near the tank and near the first lateral line. The lateral lines must be opened with at least one inspection hole in each line. This inspection hole shall be dug to the bottom of the trench. All step-down relief lines, drop boxes or distribution boxes must be demonstrated for inspection.
- e) If all of the above steps can be satisfactorily accomplished, department inspections of this type shall include a statement that this does not construe approval of this system as all parts were not available for inspection. Only those sections of the system that were fully accessed and inspected by the department will be subject to approval

**(9) SITE EVALUATION**

**(A) General**

The intent of this section is to provide standards for site evaluations based upon evaluation of the topography and landscape position; available space; and soil characteristics, primarily texture, color, structure, drainage and depth. The soil morphology evaluation is the only site evaluation method approved in Christian County. The site evaluator may choose to conduct a percolation test for comparison; however percolation tests will not be accepted or approved for a site evaluation.

**(B) Preliminary Soils Information**

The Christian County Soil Survey available from the USDA-SCS can be used to gather preliminary soils data before the actual site evaluation is conducted. The information in the soils survey is not site specific and can NOT be used in lieu of the actual site evaluation.

**(C) Site Evaluation Procedures**

All site evaluations shall be submitted on the standard site evaluation form. A minimum of one soil pit shall be dug for each represented soil area. Soil pits shall be dug to a depth of forty-eight inches (48”) or 6 inches (6”) into the restrictive horizon or as required to determine the significant soil characteristics. All proposed sites for onsite sewage treatment and disposal systems shall be evaluated for the following factors:

1. Topography, landscape position and aspect.
2. Soil Morphology which includes texture, structure, porosity, consistence, color, and other physical, mineral and biological properties of various horizons, and the thickness and arrangement of the horizons in the soil profile.
3. Soil drainage, which includes both external (surface) and internal (soil).
4. Restrictive soil horizons.
5. Soil Depth.
6. Available space.

Each of the six site factors shall be rated as being a slight, moderate or severe limitation. The most limiting factor shall determine the overall limitation rating for the site. Unless otherwise specified in this section (9), any soil factor that has an unsuitable soil characteristic shall be rated according to the following guidelines.

<b>Table VI</b>	
Depth to Unsuitable Soil Horizon	Limitation Rating
48" or greater	Slight
<b>42- 47"</b>	Moderate
<b>Less than 42"</b>	Severe

(D) **Topography and Landscape Position**

1. Represented area will be identified on the soil
2. Report using dimensions or geographic features to clearly define usable area.
3. Slopes as determined from field measurements.
4. Complex slope patterns and slopes dissected by gullies and ravines have a severe limitation due to topography.
5. Areas subject to frequent flooding shall be considered to have a severe limitation rating due to landscape position.
6. Bottomland areas, including drainage ways, shall be considered to have a severe limitation rating due to landscape position.
7. Karst features and depressions shall be considered to have a severe limitation rating.
8. Sites on or within 100 feet (100') of side slope positions within the watershed area of a sinkhole and sites within 100 feet (100') of a definable sinkhole rim shall be considered to have a severe limitation rating. Other sites within the watershed area of a sinkhole shall be considered to have a moderate limitation rating.
9. Foot-slope positions shall be considered to have a moderate limitation rating due to landscape position.

shall be used for determining the application rates. Soil texture shall be estimated by field testing. Laboratory examination of texture by particle size may be substituted for field testing.

2. Soil Consistence. Soil consistence shall be reported for soil horizons with thirty-five percent (35%) or greater clay content using wet conditions.
3. Organic Soils. Organic soils shall be considered to have unsuitable soil material characteristics.
4. Soil Structure. Block-like soil structure in Groups III, IV, and V soils shall be considered to have a moderate limitation unless the structure grade is weak enough to significantly impede water movement in which case it shall be considered unsuitable.

(E) **Soil Characteristics**

1. The texture of the different horizons of soils may be classified into five (5) general groups (Table IX) and

<b>Slope (Percent)</b>	<b>Limitations</b>
Less than 2	Moderate
2 to 20	Slight
21 to 30	Moderate
Greater than 30	Severe

<b>Soil Structure</b>	<b>Limitation Rating</b>
Block-like	moderate
Platy soil structure (considered unsuitable)	see Table VI
Massive soil structure (considered unsuitable)	see Table VI
Single grain structures	slight

(F) **Soil Drainage**

Any soil horizon that has grayish colors of chroma 2 or less (Munsell Color chart) indicative of a high water table shall be considered unsuitable as to drainage.

**Table IX. Limitation Ratings for Soil Textures**

<b>Soil Group</b>	<b>Characteristics</b>	<b>LIMITATION RATING</b>
Soil Group I	Sandy texture soils.	Slight
Soil Group II	Coarse loamy soils.	Slight
Soil Group III	Medium and fine loamy texture soils with less than thirty-five (35%) clay.	Moderate
Soil Group IV	These clayey texture soils contain thirty five percent (35%) or more clay-size particles. For evaluation purposes, "clayey soil" will indicate thirty-five percent (35%) or greater clay content. There are two (2) major types of clays: non-expandable and expandable. Soil group IVb (the expandable clays) includes soils with thirty-five percent (35%) or more rock fragments. If soil horizons in soil group IV are anticipated to have unsuitable permeability or if permeability is due primarily to the rock fragment content, (i.e., fine earth fraction has unsuitable permeability), these horizons will be placed in soil group Ivb regardless of the perceived type of clay.	
	a Non-expandable clays.	Moderate
	b Expandable clays shall be considered unsuitable soil.	
Soil Group V	This group includes all soils with a thirty-five percent (35%) or greater gravel content except for soils with a thirty-five percent (35%) or greater expandable clay content. The amount of gravel in these soils is a groundwater contamination concern due to reduced soil volume and soil-effluent contact time for treatment. Limitation ratings as to gravel content are to be given for soil deeper than twelve inches (12") below the surface.	
	I Soil with fifty percent (50%) or less gravel	Slight
	II Soils with greater than fifty percent (50%) gravel shall be considered to have a moderate LR if it is underlain by one of the following soil horizons within forty inches (40") of the surface: a limiting soil horizon, a perched seasonal high water table; a clayey horizon with no greater than fifty percent (50%) gravel; soil horizon (s) with a minimum of two feet (2') of loamy or sandy soil with less than thirty-five (35%) gravel.	Moderate
	III Soils with greater than fifty percent (50%) rock fragments that do not meet the subsoil criteria for a moderate LR shall be considered to have a severe LR	Severe

**(G) Soil Depth**

Soil Thickness will represent the depth to bedrock or paralithic (soft bedrock) contact. Soil depth limitation ratings shall be as in **Table X**. This limitation rating shall be determined by the shallowest known point within the **representative area**.

Depth to Bedrock	Limitation Rating
48 inches or greater	Slight
36 to 47 inches	Moderate
Less than 36 inches	Severe

**(H) Restrictive Horizons**

Restrictive horizons severely restrict the movement of water and air and shall be considered unsuitable. These restrictive horizons shall not be breached. Restrictive horizons may occur as any of the various forms of pans.

**(I) Available Space**

The available space shall be estimated on the area needed for a standard system with a .4gpd/sq.ft LDR or the specified LDR, whichever is less. Portions of the property outside of the represented soils area may be considered in determining available space for an alternate field if there are no surface features indicating the outside area is inappropriate for an absorption field. Lots that appear to have adequate space for two absorption fields shall be given a slight LMR. Lots that appear to have sufficient area for one absorption field, but may not for two fields shall be given a moderate LMR. Lots that appear not to have adequate space for one absorption field shall be given a severe LMR. The precise determination of available space will be determined by the system designer. A severe LMR due to limited space will be overridden by the design plan and automatically changed to moderate if the plan shows adequate space.

LMR = Limitation Rating

LDR = Loading Rate

**(J) Other Applicable Factors**

The site evaluation should include consideration of any other applicable factors involving environmental principles including:

1. The proximity of a large capacity water supply well, the cone of influence of which would dictate a larger separation distance than the minimum specified in these standards.
2. The potential environmental hazard of possible failures of soil absorption systems involving large amounts of sewage, which would dictate larger separation distances than the minimums specified in these standards; and
  1. The potential environmental and health hazard of possible massive failures of soil absorption systems proposed to serve large numbers of residences, as in residential subdivisions or mobile home parks.

**(K) Severity Ratings**

Soil factors with a severe limitation rating due to permeability restrictions as indicated by a seasonally high water table or a limiting layer shall be given a specific severity rating based on the following guidelines. The rating will be on a scale from one (1) to five (5) with one (1) being slightly severe and five (5) being highly severe. The severity rating is based on the site's potential for subsurface lateral water movement. As the severity rate increases the site's potential for subsurface lateral water movement decreases and the site's potential for saturated soil conditions at detrimental depths, frequencies, and durations increases. Specific site criteria are given for a severity rating of one (1). Severity ratings of two through five (2-5) are based on the site evaluator's experience and professional opinion. Severity ratings of two through five (2-5) are subjective, and the administrative authority reserves the right to accept or reject them on a case by case basis.

**Table XI**

Severity Rating	Site Criteria
SV-1	Minimum of twenty-four inches (24") to a seasonal high water table (SHWT) or limiting layer, no low chroma or reddish mottles due to moisture conditions observed within 24" of surface, less than thirty-five percent (35%) clay in all soil above SHWT or limiting layer, minimum slope of two percent (2%). - or - Minimum of eighteen inches (18") to seasonal high water table (SHWT) or limiting layer, minimum rock content of thirty-five percent (35%) in twelve inch (12") zone above the SHWT or limiting layer, less than thirty-five percent (35%) clay in soil above SHWT or limiting layer, minimum slope of four percent (4%). <b>These soils need and shall require, at a minimum, a "shallow placement" system. A curtain drain will be required if the SHWT or limiting layer is less than 30 inches.</b>
SV-2	<b>These soils do not meet the soil criteria for a SV-1 classification; however, they are evaluated to be adequate for the same minimum system criteria as for SB-1 soils.</b>
SV-3	These soils are severe enough to create a significantly higher potential for surfacing effluent compared to non-severe sites. Relevant site factors are anticipated to be severe enough to necessitate one of the following systems: LPP system; Standard shallow placement absorption trench system with pump or siphon distribution (non-serial); Black /gray water system; Other Department approved system.
SV-4	Relevant site factors are anticipated to be highly questionable for the utilization of a subsurface absorption trench system and the site needs to be considered to have a high potential for surfacing effluent for a standard system. These sites, if permitted for a sub-surface absorption trench system, shall require a system with a pretreatment component, <b>and a distribution system adequate to maintain effluent below the surface.</b>
SV-5	Relevant site factors are anticipated to be unsuitable for <b>consistently retaining effluent below the surface. If a system is permitted for this site a pretreatment component shall be required and the soil report shall state that it is anticipated that any potentially surfacing treated effluent will be retained on site.</b>

**(L) Design Recommendations**

The site evaluator shall provide the following recommendations:

1. Trench Depth - Specify a trench depth for proposed absorption trench system in accordance with the standards.
2. Loading Rate - Specify a loading rate for proposed absorption trench system.
3. Curtain Drain - If a curtain drain is required by the standards and it appears to be technically feasible, one shall be specified with a construction depth. The evaluator shall also recommend a curtain drain when not specified in the standards if there is anticipated to be an excessive amount of subsurface lateral water flow into the absorption field affecting wastewater disposal or treatment. This excessive water flow may be due to the landscape position, large drainage area and/or soil factors conducive to lateral movement of subsurface water.
4. Sand-lined trenches - Specify sand-lined trenches if they are necessary for compliance with the standards.
5. Systems – specify, at least one appropriate system that is necessary to comply with the standards. Other alternative systems may be listed if the site evaluator believes one is needed to comply with the standards. A system does not have to be listed for severe soils with a severity rating greater than three (3).
6. Wastewater Ponds - If the site meets the minimum criteria for a pond and one is to be proposed, the evaluator shall list the site's main limitations for a wastewater pond and provide needed recommendations to assist in overcoming those limitations unless the evaluator believes the site is inappropriate for a wastewater pond.
7. In watershed areas of sinkholes, if the site evaluator does not believe the site is clearly at least 100 ft. up-slope of the elevation of the spillover point of the sinkhole then the site evaluator shall specify the need for the determination of the sinkhole overflow elevation line (soel) with a level or a sinkhole report.
8. Unusable sites - The site evaluator shall designate a site unusable if it has a severity rating of five (5) and there appears to be an insufficient area to prevent the potential surfacing effluent, following an advanced treatment system, from creating a potential public nuisance situation.

(M) **Loading Rates**

Table XII shall be used when determining the application rate for wastewater systems of standard design when using the site evaluation criteria in this appendix:

<b>Table XII</b>			
<b>SOIL GROUP</b>	<b>SOIL TEXTURE GROUPS</b>	<b>SOIL TEXTURE CLASSES</b>	<b>LOADING RATE gpd/sq.ft. (Conventional)</b>
1	Sands	Sand Loamy Sand	1.2 - 0.8
2	Coarse loams	Sandy loam	0.8 - 0.6
3	Medium & Fine loams < 35% clay	Silt loam Clay loam Sandy clay loam Silty clay loam	0.6 - 0.4
4a	Clays, fine loams (≥ 35% clay) low to moderate shrink/swell	Sandy clay Silty clay Clay Silty clay loam Clay loam	0.4 - 0.2
4b	Clays, fine loams (≥35% clay) high shrink/swell	Sandy clay Silty clay Clay Silty clay loam Clay loam	Unsuitable
5	Skeletal low to moderate shrink/swell in textures with ≥35% clay	All textures	0.6 - 0.4

Application rates as shown in Table XIII shall be used in determining minimum area for low pressure pipe systems when using the site evaluation criteria in this appendix: The construction of any conventional or LPP system must meet the other applicable requirements as set forth in sections (5) and (8) of this rule.

Table XIII Low Pressure Pipe			
SOIL GROUP	SOIL TEXTURE GROUPS	SOIL TEXTURE CLASSES	LOADING RATE gpd/sq.ft. (Low Pressure Pipe)
1	Sands	Sand Loamy sand	0.5 - 0.4
2	Coarse loams	Sandy loam	0.4 - 0.3
3	Medium & Fine loams < 35% clay	Silt loam Clay loam Sandy clay loam Silty clay loam	0.3 - 0.2
4a	Clays fine loams (≥35% clay) low to moderate shrink/swell	Sandy clay Silty clay Clay Silty clay loam Clay loam	0.2 - 0.1
4b	(Same as conventional)		
5	Skeletal low to moderate shrink/swell in textures with ≥35% clay	All textures	0.3 - 0.2



# FORMS & DRAWINGS

Wastewater Treatment Systems <b>Permit Application</b>		
<i>Applicant Completes This Section</i>	Date Submitted _____	
Owner Name: _____	Phone _____	
Mailing Address: _____		
Property Address and Directions to Site (Include road names and numbers): _____		
Required Signatures:		
_____	_____	_____
Owner or Legally Authorized Representative	Installer	Daytime Phone Number
System Flagged or Identified Yes <input type="checkbox"/> No <input type="checkbox"/> (if no, installer must inform CCHD prior to pre-site visit) Date informed _____		

**NOTE: The design, construction, operation and maintenance of on-site wastewater treatment systems shall be the responsibility of the designer, owner, developer, installer or user of the system. Actions by the Christian County Health Department to effect compliance with the provisions of the Christian County Wastewater Ordinance shall in no way be taken as a guarantee or warranty that on-site wastewater treatment systems approved and permitted will function in a satisfactory manner for any given period of time.**

FOR HEALTH DEPARTMENT USE ONLY																															
Fee \$ _____	Paid by: _____	Date _____	Receipt # _____																												
Date/Initial _____	Approved	Notified: Date _____	Phone/Left Mess. In Office _____																												
_____ <b>Pre-construction Inspection</b>	<input type="checkbox"/> Yes <input type="checkbox"/> No	<table style="width:100%; border-collapse: collapse;"> <tr> <td>DB</td> <td>SD</td> <td colspan="2">DIST. BOX</td> </tr> <tr> <td>SHL</td> <td>STD</td> <td>BLK/GREY</td> <td>LEVEL LPP</td> </tr> <tr> <td>GVLS</td> <td></td> <td>SAND</td> <td>EZ-FLOW</td> </tr> <tr> <td>HOLD. TANK</td> <td></td> <td>DEF SITE</td> <td>PMP</td> </tr> <tr> <td>CD</td> <td></td> <td></td> <td></td> </tr> <tr> <td colspan="4">OTHER _____</td> </tr> <tr> <td>RIT I.</td> <td>FINI FY</td> <td>IAMES</td> <td>SAC SWAN</td> </tr> </table>		DB	SD	DIST. BOX		SHL	STD	BLK/GREY	LEVEL LPP	GVLS		SAND	EZ-FLOW	HOLD. TANK		DEF SITE	PMP	CD				OTHER _____				RIT I.	FINI FY	IAMES	SAC SWAN
DB	SD			DIST. BOX																											
SHL	STD			BLK/GREY	LEVEL LPP																										
GVLS				SAND	EZ-FLOW																										
HOLD. TANK		DEF SITE	PMP																												
CD																															
OTHER _____																															
RIT I.	FINI FY	IAMES	SAC SWAN																												
_____ <b>Review of Changes</b>	<input type="checkbox"/> Yes <input type="checkbox"/> No																														
_____ <b>Modification</b>	<input type="checkbox"/> Yes <input type="checkbox"/> No																														
_____ <b>Renewal</b>	Reminder call for exp. date _____																														
Amount Pd. \$ _____	_____																														
_____ <b>Permit Canc./Trans. To:</b>	_____																														
_____ <b>Transfer</b>	<input type="checkbox"/> New Sketch <input type="checkbox"/> Original Sketch																														
Amount Pd. \$ _____	_____																														
Prev. Installer _____	_____																														
Prev. Permit # _____	_____																														
Note: _____	Bedroom # _____																														

FINAL INSPECTION REPORT	
<b>Installer <u>must</u> provide copy of signed final inspection report to owner.</b>	
<input type="checkbox"/> Loamy soil cover on site	_____
<input type="checkbox"/> Pump tested/electric connection by:	_____
<input type="checkbox"/> Building sewer connection to treatment plant	_____
Final scheduled by _____	Date _____ Canceled <input type="checkbox"/> Date _____ Rescheduled <input type="checkbox"/> Date _____
Approved by: _____	Date: _____
Health Department Representative	
<b>San 2</b>	

AN EQUAL OPPORTUNITY/AFFIRMATIVE ACTION EMPLOYER  
 Services provided on a nondiscriminatory basis.

**SKETCH PLAN (CONVENTIONAL SYSTEM)**

**DRAWN BY:** \_\_\_\_\_

**FOR:** \_\_\_\_\_

N  
W E  
S

**Note:** Show reference points for location of system (such as pits).

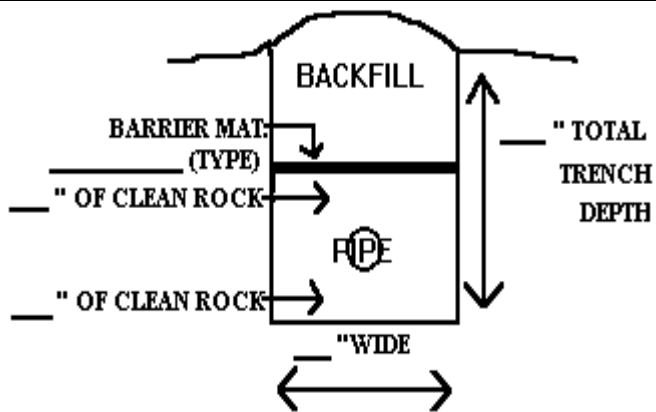

GRAVEL SIZE \_\_\_\_\_  
 GRAVEL TYPE \_\_\_\_\_  
 GRAVELESS PIPE SIZE \_\_\_\_\_

**Design Details (fill in the blanks)**

\_\_\_\_\_ Ft. of 4" SCD 40 between house and tank  
 \_\_\_\_\_ Ft. of 4" SCD 40 from tank to lateral field  
 \_\_\_\_\_ Gallon concrete septic tank  
 \_\_\_\_\_ (size) gravel bedding for tank  
 \_\_\_\_\_ % slope in lateral field  
 \_\_\_\_\_ Bedroom home  
 \_\_\_\_\_ Ft. setback to P/L  
 \_\_\_\_\_ Ft. setback to well  
 \_\_\_\_\_ Ft. setback to waterlines  
 \_\_\_\_\_ (size) Schedule 40 solid pipe and fittings  
 \_\_\_\_\_ Perforated Pipe strength  
 \_\_\_\_\_ Curtain Drain depth  
 \_\_\_\_\_ Ft. to Sinkhole rim or flooding elevation

Well  Public  Private  
 Community  
 Private



CHRISTIAN COUNTY HEALTH DEPARTMENT
ENVIRONMENTAL DIVISION
P. O. BOX 340
OZARK, MO 65721
581-8183

HOLDING TANK ACKNOWLEDGMENT

Date \_\_\_\_\_

I fully understand that the Christian County Health Department does not encourage the use of holding tanks due to excessively high costs of operation.

Check which situation applies to this system:

(A) [ ] The holding tank serving \_\_\_\_\_ is for temporary use for one (1) year from this date. It is agreed that \_\_\_\_\_ will be connected to a permitted on-site wastewater treatment system or to the City of \_\_\_\_\_ Municipal Wastewater System within one (1) year from the date of this agreement.

Or

(B) [ ] This holding tank is for minimal use of eight hour shift employees only. This system has special requirements in addition to those listed in the wastewater standards. Those requirements are as follows: \_\_\_\_\_

Or

(C) [ ] This holding tank is for other use that has been authorized by Christian County Health Department.

(C:1) Usage details \_\_\_\_\_

Holding tank test performed annually [ ] Yes [ ] No
(A charge will be incurred annually by the owner for performance of this test)

Owner signature \_\_\_\_\_

**CHRISTIAN COUNTY HEALTH DEPARTMENT  
ENVIRONMENTAL DIVISION  
P.O. BOX 340  
OZARK, MO 65721  
417-581-8183**

To: \_\_\_\_\_

Date: \_\_\_\_\_

Subject: Pre-construction review for \_\_\_\_\_ permit application.  
The above application/sketch was reviewed on \_\_\_\_\_. Items addressed in comments must be addressed prior to proceeding with construction. Note: Inspectors check the appropriate items available on the sketch plan and application.

---

**APPLICATION FORM**

- Owner's name/address
- Precise directions to site
- Owner's signature

**COMMERCIAL SYSTEMS**

- Calculations for flow rate
- Calculations for tank size
- Calculations for dosing rate

---

**SKETCH PLAN**

- Building sewer-pipe size
- Cleanout (s)
- Number of bedroom house
- Septic tank size/construction
- Pump tank size/construction
- Specific slope in lateral field
- Surface drainage
- Curtain drain depth
- Vertical drain depth
- Setback to \_\_\_\_\_
- System located in area of represented soils
- Represented area clearly defined
- Location of well/waterlines

- Solid Pipe Strength/Length
  - Between house and tank
  - Between tank and absp field
  - Step down (relief lines)
  - Drop box to lateral
  - Between drop boxes
  - Dist. Box to lateral
- Trench Details
  - Width/Depth
  - Perforated pipe strength
  - Length of trench
  - Distance between trenches
  - Depth of gravel below/above pipe
  - Barrier material and type
  - Caps on ends of pipe
  - Ends connected of line at equal elev.
  - Sand-lined trenches
  - Fill properly incorporated

N  
      W      E  
                    S

---

**LAGOON**

- Setbacks met
- Pond construction
- Lagoon size appropriate

---

**LPP SYSTEMS**

- Sketch includes ball valves
- Sketch includes turn-ups at trench ends
- Sketch includes length of manifold
- Sketch includes size of manifold pipe (SCD 40 or 160 psi)
- Sketch includes size of lateral pipe
- Completed worksheet
- Completed design summary sheet

Comments:

\_\_\_\_\_  
\_\_\_\_\_  
\_\_\_\_\_

Provide the required information to the health department identified in comments.

\_\_\_\_\_  
SAN-11 (Rev. 7-2015) Signature of Christian County Health Department Rep.

CHRISTIAN COUNTY HEALTH DEPARTMENT  
ENVIRONMENTAL  
301 E BRICK  
PO BOX 340  
OZARK, MO 65721

### Variance Request

**Items needed:**

1) Explicit reason why the required setback distance(s) cannot be complied with. (Please attach explanation if more space is needed). \_\_\_\_\_

\_\_\_\_\_  
\_\_\_\_\_  
\_\_\_\_\_

2) Potential impact, if any on neighboring property owners. \_\_\_\_\_

\_\_\_\_\_  
\_\_\_\_\_

### Adjacent Landowners

**Items needed:**

1) Portion of tax map showing adjacent landowners. (Available at the Christian County Assessors office).

2) Copy of index card corresponding with tax map. (Available at the Christian County Assessors office).

I, \_\_\_\_\_, have obtained from the Christian County Assessors office adjacent landowners names and addresses. These have been supplied to the Christian County Health Department on this date \_\_\_\_\_.

Please attach the records to this form.

**Letters are sent Certified Mail.** Enclosed is \$\_\_\_\_\_ (certified mail fee) for \_\_\_\_\_(number of letters).

**Owners Signature** \_\_\_\_\_ **Date** \_\_\_\_\_

**Property Address** \_\_\_\_\_ **City** \_\_\_\_\_ **Zip** \_\_\_\_\_

**Mailing Address** \_\_\_\_\_ **City** \_\_\_\_\_ **Zip** \_\_\_\_\_

## CURTAIN DRAINS

Curtain drains intercept laterally moving perched water tables caused by a shallow, impermeable restrictive horizon. Curtain drains are placed a minimum of six inches (6") into the top of the restrictive horizon and filled with gravel to the same depth as the perched water table. Perforated pipe (not coiled tubing) is placed in the bottom of the trench with the holes pointed up toward the perched water table and away from the lateral field. If the site has sufficient slope, the drains are brought to the surface downslope to allow free drainage and the ends are screened. On level sites, pumps must be used to remove the collected water.

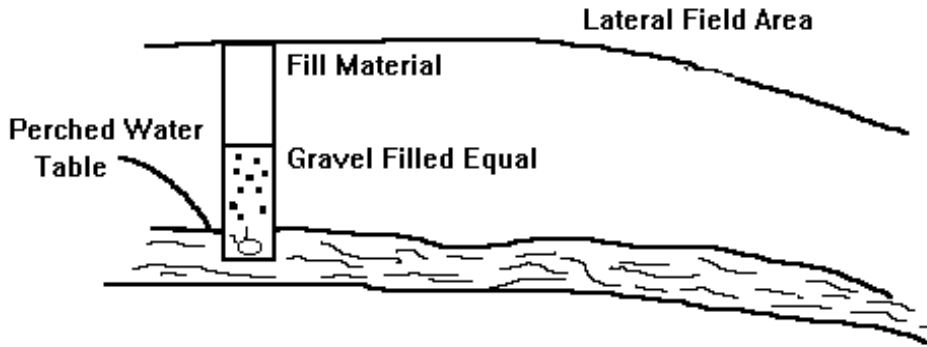

## VERTICAL DRAINS

If the restrictive layer is thin and overlies permeable soil, vertical drains may be used. The trench is excavated through the restrictive layer into the more permeable soil below and backfilled with porous material.

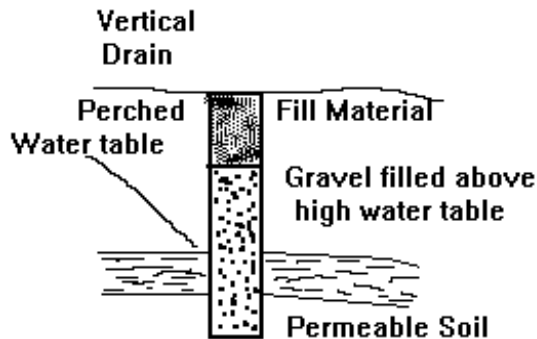

### EXAMPLE: SHALLOW PLACEMENT

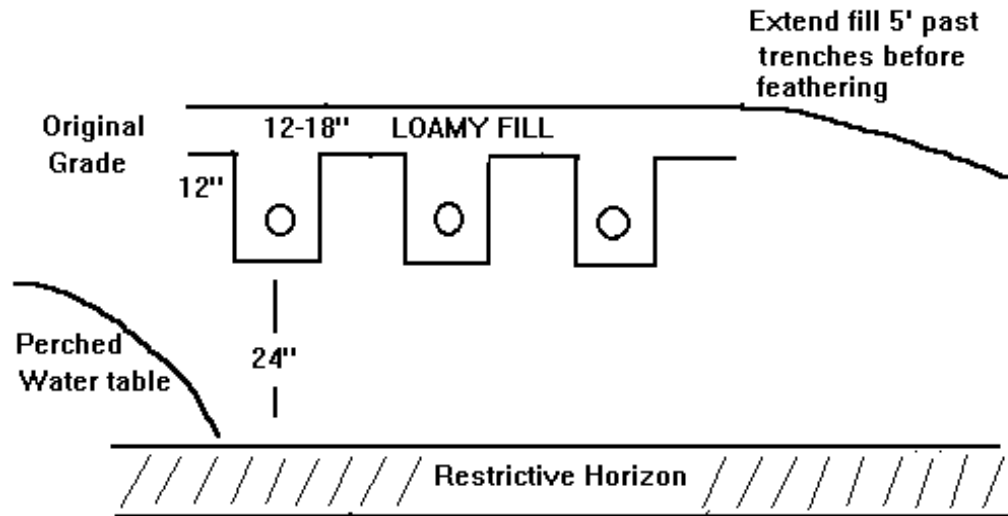

### EXAMPLE: MODIFIED SHALLOW PLACEMENT

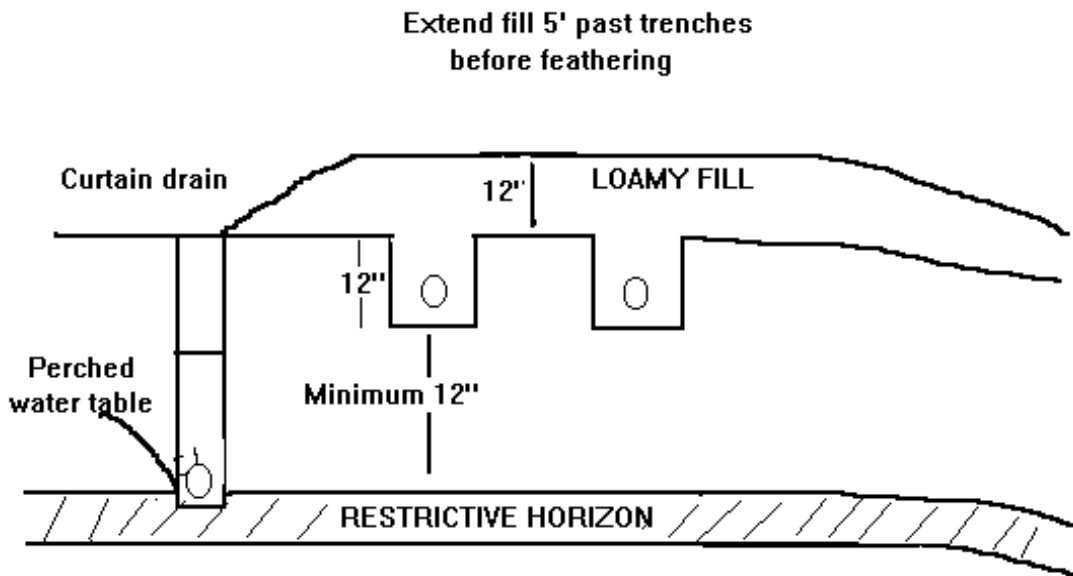



## EXAMPLES: STEP-DOWN SYSTEMS

Laterals must follow contours

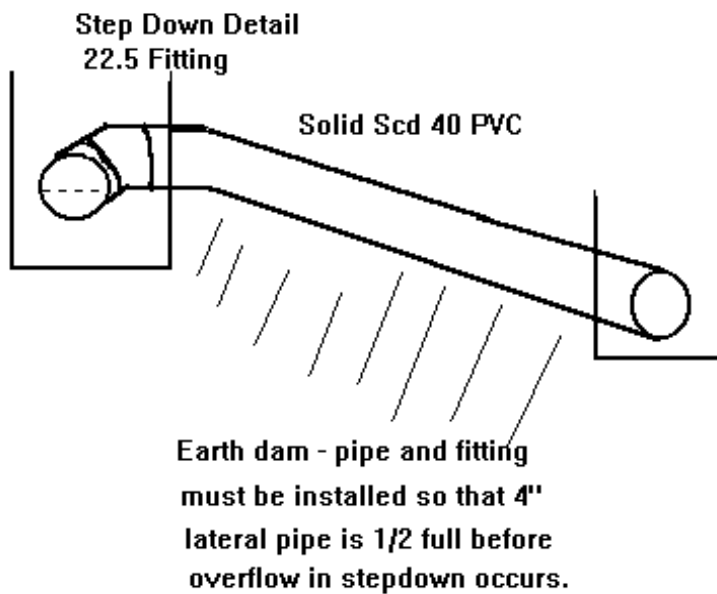
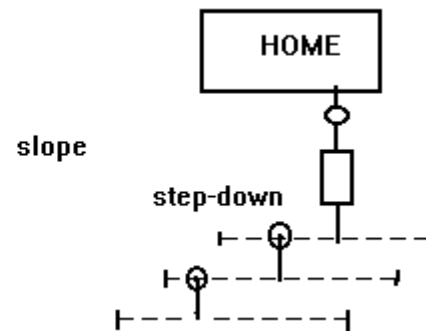
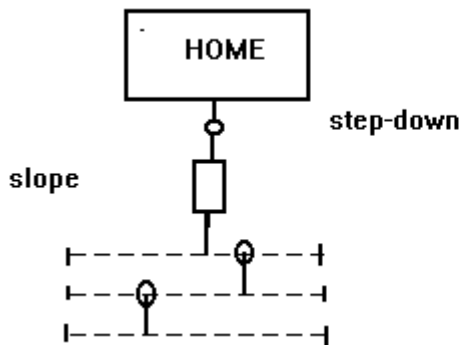
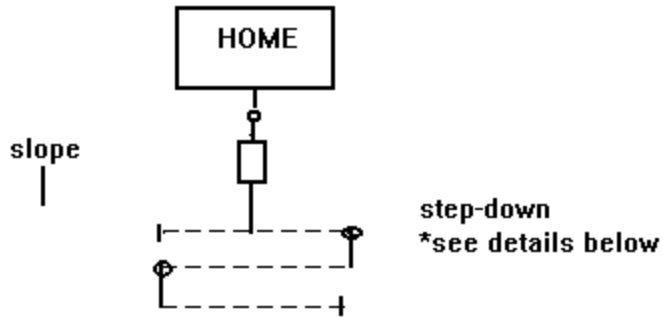

## DROP BOX SYSTEMS

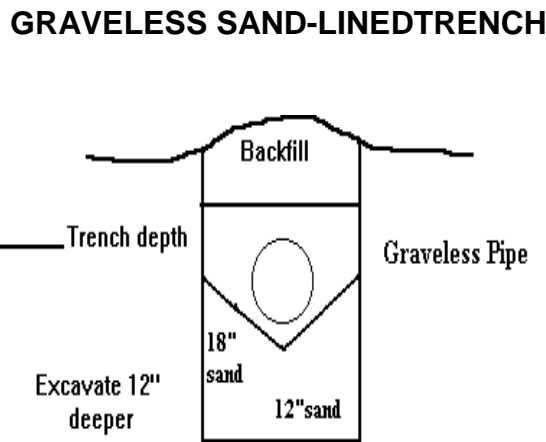
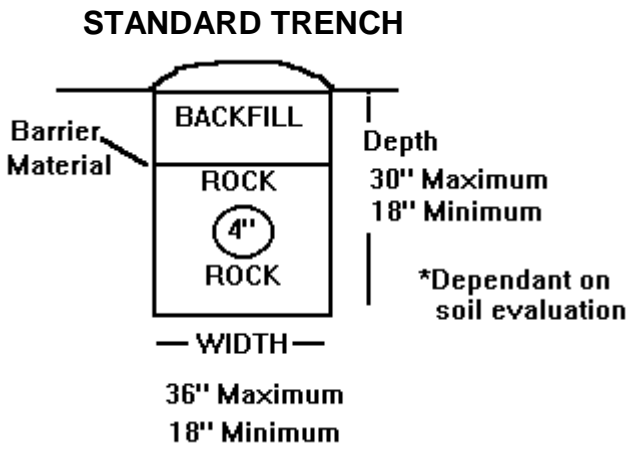
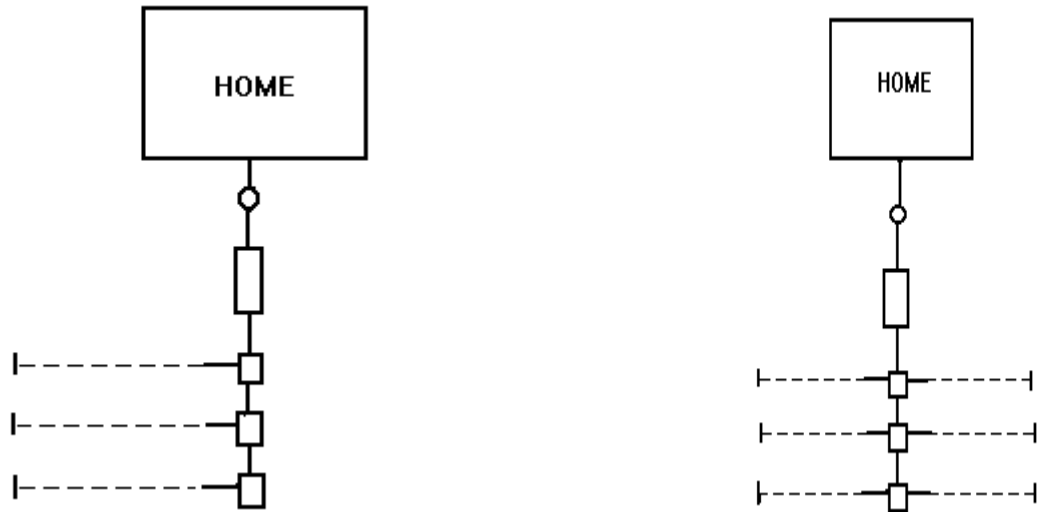

## Formulas

**Daily flow = # of bedrooms x 120 for residence. Commercial is based on Table II page 33, or submitted and approved actual flow data.**

Septic tank sizing =  $V = 1.5Q + 500$  for sizing tanks other than specified on page 38.

Absorption Area = gpd divided by loading rate = sq. foot of trench.

Linear footage of trench = sq. foot of trench divided by effective width of trench in feet.

# Index

## A

absorption field  
    gravity fed, **35**  
absorption systems, **2, 22, 33, 36, 37, 38, 39, 40, 47**  
absorption trench, **28, 34, 35, 36, 37, 38, 39, 48**  
access manhole, **27**  
Aeration Unit, **32**  
Alluvium, **18**  
Alternative Systems, **42**  
Application form, **12**  
Application processing, **12**

## B

backfill, **28, 36, 38**  
Baffle, **18**  
barrier material, **36, 39, 44**  
bed system, **38**  
bedrock, **19, 20, 21, 29, 34, 40, 47**  
Black water, **18**  
Building sewer, **9, 18, 28**

## C

caps, **22, 36**  
chamber system, **38**  
Chamber System, **38**  
cleanout, **22, 28, 40**  
Complex slope, **36**  
contour, **36**  
corrugated pipe, **20, 35**  
curtain drain, **34, 39, 48**

## D

Damage Renovation, (Replacement and Repair) to  
    Properly Functioning Permitted Systems, **43**  
Deficient replacement site, **24**  
distribution lines, **35, 36, 37**  
Distribution pipes, **18**  
Diversion berms, **39**  
diversion valve, **39**  
Dosing  
    required, **37**  
    dosing device, **18**  
    Dosing/alternating systems, **38**  
drop boxes, **35, 36, 37, 43, 44**

## E

Easements, **24**  
Effluent distribution devices, **36**

Elevated Sand Mound, **42**

## F

fall, **21, 28, 36**  
Fee schedule, **16**  
Filtered pump vault, **32**  
final inspection, **13**  
Flow Rate, **23**

## G

gravelless system, **37, 38**  
gray water, **26, 27, 34, 35, 41, 48**  
    tank, **41**  
Grease trap, **19**

## H

Holding Tank, **41**  
holidays, **13**

## I

Inlet and outlet connections, **29**  
inspection, **36**  
interceptor drains, **23, 36**  
Intermittent sand filters, **19**  
invert, **22, 37**

## L

lagoon, **21, 23, 42**  
level system, **36**  
License and Registration Program, **7**  
liquid depth, **29**  
low pressure pipe, **19, 22, 34, 35, 42, 50**

## M

MDNR, **5, 6, 7, 8, 9, 12, 24**  
Minimum Setback Distances., **23**  
modification, **12, 13, 20**  
modified sketch, **13**  
Modified standard, **20**  
Mottling, **20**  
Mound system, **20**

## N

NEMA, **32**

## O-R

Other Systems, **42**  
Perforated pipe, **35, 39, 59**  
Polystyrene Aggregate Absorption Field, **20**  
Renovation to Systems Installed Prior to May 1, 1992, **43**

Represented area, **45**  
revocation, **7, 8, 14, 15**  
Rock, **36**  
Rock fragments, **21**

**S**  
sand filter, **23, 42**  
Sand-lined trenches, **39**  
sand-lined trenches, **35, 36, 38**  
sanitary tees, **18, 29**  
septage, **31**  
Septic Tank Filters, **31**  
Setback, **21**  
setback variance, **24**  
Sewage Flow, **1, 23**  
sewage tank, **18, 22, 24, 28, 29, 31, 34, 36**  
Sewage Tanks  
    access, **29**  
    compartmentation, **30**  
    Location, **31**  
shallow placement, **32, 34, 35, 37, 38, 39, 42, 48**

sinkholes, **7, 20, 21, 22, 24, 48**  
site evaluation, **8, 12, 24, 28, 43, 44, 47, 49, 50**  
Site Information, **3**  
slope, **6, 22, 23, 26, 27, 28, 34, 35, 36, 37, 38, 45, 48, 59**  
Soil pits, **28, 44**  
Soil textural classification, **21**  
Soil treatment area, **22**  
Solids Removal, **31**  
standard system, **42, 47, 48**  
stepdowns, **35, 37**

**T-Z**  
tanks, **12, 22, 23, 26, 29, 30, 31, 32, 33, 37, 41, 43, 62**  
treatment. *See* Introduction **2**  
trench rock, **18, 22, 44**  
Valve box, **22**  
Vertical Drains, **59**  
vertical separation, **34**  
Wastewater Stabilization Ponds, **40**  
Wetlands, **42**